

Meteosat First Generation User Handbook

Doc.No. : EUM/OPS/USR/10/1537
Issue : v1
Date : 30 June 2010
WBS :

EUMETSAT
Eumetsat-Allee 1, D-64295 Darmstadt, Germany
Tel: +49 6151 807-7
Fax: +49 6151 807 555
<http://www.eumetsat.int>

Document Signature Table

Removed for Internet Publication.

Document Change Record

<i>Issue / Revision</i>	<i>Date</i>	<i>DCN. No</i>	<i>Changed Pages / Paragraphs</i>
V1.0	28.06.2010		Ported from 'The Meteosat Archive – User Handbook, EUM TD 06 – Issue 2.6A'

Table of Contents

1	INTRODUCTION	4
1.1	Purpose and Structure	4
1.2	MFG Documentation	4
1.2.1	Format Guides	4
1.2.2	BUFR Templates	4
2	OVERVIEW	5
2.1	Introduction	5
2.2	EUMETSAT and the Meteosat First Generation	5
2.3	Historical Data Handling	7
3	INTRODUCTION TO IMAGE DATA	8
3.1	Overview	8
3.2	Basic Image Navigation	10
3.3	Product Sizing	10
4	INTRODUCTION TO METEOROLOGICAL PRODUCTS	11
4.1	Overview	11
4.2	Product Sizing	14
5	DATA GEOLOCATION AND GEOCODING	15
5.1	Introduction	15
5.2	Image Data Navigation	15
5.2.1	Basic Terminology and Formulae	16
5.2.2	Digital Coordinate Geometry	19
5.2.3	Point Conversion (Geographic to Digital)	21
5.2.4	Point Conversion (Digital to Geographic)	26
5.3	Meteorological Product Navigation	31
6	DIGITAL DATA DISTRIBUTION FORMATS	32
6.1	Introduction	32
6.2	File Formats	32
6.3	Delivery Methods	33
7	IMAGE DATA PRINTS	33
8	USING THE SERVICES	34
8.1	Introduction	34
8.2	Requesting Documentation	34
8.3	Searching for Data	34
8.4	Ordering Products	34

1 INTRODUCTION

1.1 Purpose and Structure

This historical document describes the Meteosat First Generation (MFG) products and services available from the EUMETSAT Data Centre Archive. The Archive guarantees the long-term preservation of data and generated products from EUMETSAT's meteorological satellites. It enables users to browse, make automated orders and retrieve data from EUMETSAT's catalogue of products.

The document is structured as follows:

- Section 2 EUMETSAT's overall responsibilities and Ground Segment activities
- Sections 3 and 4 respectively introduce the image data and derived meteorological products available from the archive
- Section 5 explains how the data can be navigated, so that specific measurements in the data can be related to terrestrial latitudes and longitudes
- Sections 6 and 7 describe respectively the digital and printed formats which are available for disseminating data from the archive
- Section 8 presents the services offered by the archive and explains how to use them.

A number of appendices are also included and provide more information on data formats and how to order archived data.

1.2 MFG Documentation

This document is intended to provide historical information needed to understand and request MFG data from the archive. The documents described below are available from the EUMETSAT web site and may also be requested in hardcopy from the User Service (see Section 8 for contact details).

1.2.1 Format Guides

A series of Format Guides define the exact formatting of each orderable data product, and can be used to assist data decoding and interpretation. These documents may be viewed on the EUMETSAT web site at:

[http://www.eumetsat.int/Home/Main/Documentation/Technical and Scientific Documentation/Format Guides/index.htm](http://www.eumetsat.int/Home/Main/Documentation/Technical_and_Scientific_Documentation/Format_Guides/index.htm)

1.2.2 BUFR Templates

For those products available in the WMO BUFR code, templates are available on the EUMETSAT web site at:

[http://www.eumetsat.int/Home/Main/Access to Data/Meteosat Meteorological Products/BUFR GRIB2/?l=en](http://www.eumetsat.int/Home/Main/Access_to_Data/Meteosat_Meteorological_Products/BUFR_GRIB2/?l=en)

2 OVERVIEW

2.1 Introduction

This section provides some summary information on EUMETSAT and the Meteosat satellites. It concentrates on aspects directly relevant to understanding the data available from the Meteosat Archive.

2.2 EUMETSAT and the Meteosat First Generation

In December 1995 EUMETSAT took over direct responsibility for the reception, processing, dissemination and archiving of European meteorological satellite data from the Meteosat First Generation satellite series. These functions had previously been carried out by ESA on EUMETSAT's behalf at the European Space Agency Operations Centre (ESOC).

In preparation for this, EUMETSAT implemented a major new Ground Segment. The central facilities of the Ground Segment are located in EUMETSAT's Headquarters in Darmstadt, Germany. These facilities are:

- The Core Facility (CF), responsible for satellite control, telemetry monitoring, data reception, image processing and data dissemination.
- The Meteorological Products Extraction Facility (MPEF), responsible for processing received images to create a range of derived meteorological and climatological products.
- The Meteorological Archive and Retrieval Facility (MARF), responsible for archiving of image data and derived products, and the retrieval and dissemination of these products for users. Note the MARF is now replaced by the Unified MARF and this is part of the EUMETSAT Data Centre Archive.

The overall architecture of the Ground Segment is illustrated in Figure 2.1.

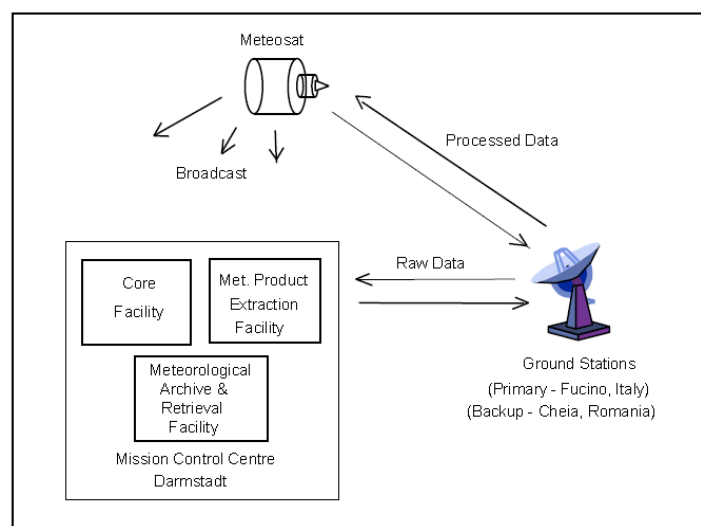

Figure 2.1 MTP Ground Segment Architecture

Incoming image data are received at the Primary Ground Station (PGS) in Fucino, Italy or the Backup Ground Station (BGS) in Cheia, Romania and relayed to the Mission Control Centre in Darmstadt. Once processed, the images are relayed back to the satellite for broadcast to users possessing Primary and Secondary Data User Systems (PDUS/SDUS). Some data are also disseminated via the Global Telecommunication System (GTS) of the World Meteorological Organization (WMO).

Figure 2.2 shows the main internal data flows within the Mission Control Centre.

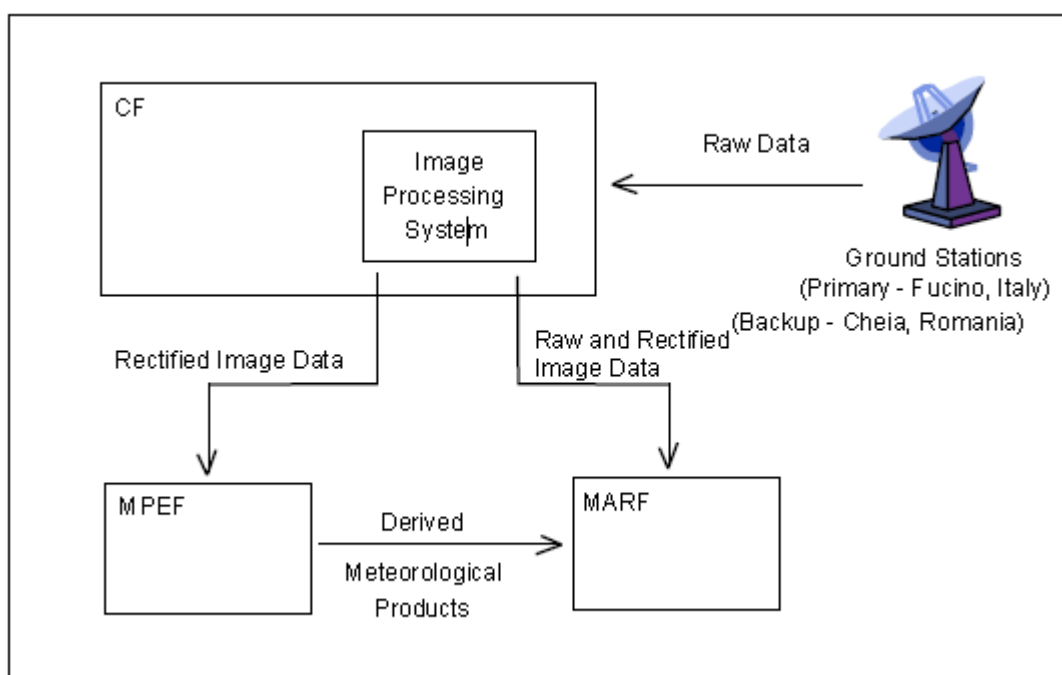

Figure 2.2 MTP Ground Segment Architecture

Within the Core Facility, image data are received and processed by the Image Processing System (IPS). The IPS performs a number of operations on the data, adding calibration and other ancillary information. The most important operation is rectification, in which geometric and radiometric distortions associated with the image sensor performance and satellite position are removed. Images which have been rectified are exactly centred and geometrically correct.

The IPS outputs both rectified and un-rectified data streams. Rectified data are broadcast to the users and are also passed to the MPEF for use in meteorological product derivation. Both Rectified and un-rectified data are ingested into the EUMETSAT Data Centre Archive.

The MPEF produces a number of derived meteorological products. These products are generated at different intervals, and are also ingested into EUMETSAT Data Centre Archive as well as being disseminated in near real-time to the user community.

2.3 Historical Data Handling

In addition to archiving new data received from the EUMETSAT satellite series, the Data Centre Archive has also taken over the historical archive built up by ESOC. This consisted of some 40,000 magnetic tapes, covering the period 1978-1995, in various formats. To secure the long-term future of the data, EUMETSAT has systematic transcribed this historic data into the archive. Some facts should be noted when ordering older data:

- Not all ancillary data are available for all older data, although the basic image pixels are always present.
- Although every effort is made to rectify image data when requested, the success of this process cannot always be guaranteed for some of the historical data due to unexpected format variations and data anomalies.

3 INTRODUCTION TO IMAGE DATA

3.1 Overview

Image products contain the basic image data acquired by the Meteosat satellites. These data are normally obtained every 30 minutes in three spectral wavebands. Since the satellites are in equatorial geostationary orbit, the coverage is approximately hemispherical and centred on the sub-satellite longitude crossing with the equator.

Throughout the Meteosat programme the main operational satellite has been and will continue to be located over 0° longitude (the Greenwich meridian). In fact, the equatorial location of the geostationary orbit means that the key European coverage is well to the north of the image, towards the limb, and the images are therefore dominated by the continent of Africa. In the last few years, this African coverage has become of increasing interest, and EUMETSAT, in co-operating with the WMO, is working with meteorological agencies in Africa to help them to exploit this resource. In addition to Africa and Europe, the normal full disc view from Meteosat features the Middle East and the Atlantic Ocean.

Several usable Meteosat satellites are typically in orbit at any one time, and EUMETSAT has on occasion used one of the back-up satellites to provide additional coverage outside the European area. Most notably, the Atlantic Data Coverage (ADC) and Extended Atlantic Data Coverage (X-ADC) programmes positioned Meteosat satellites over the Western Atlantic, where for a period of several years they filled a gap in the world-wide meteorological satellite network resulting from a gap in the United States GOES programme. Of these two programmes, only data from the ADC programme are currently stored in the Meteosat Archive. In addition since 1995 EUMETSAT has relocated a Meteosat satellite over longitude 63° E in support of the Indian Ocean Data Coverage (IODC) service.

The imagery itself consists of rectangular arrays of 8-bit image pixels. The satellite is spin-stabilised, and the data are acquired at the rate of one image line per satellite rotation (see Figure 3.1).

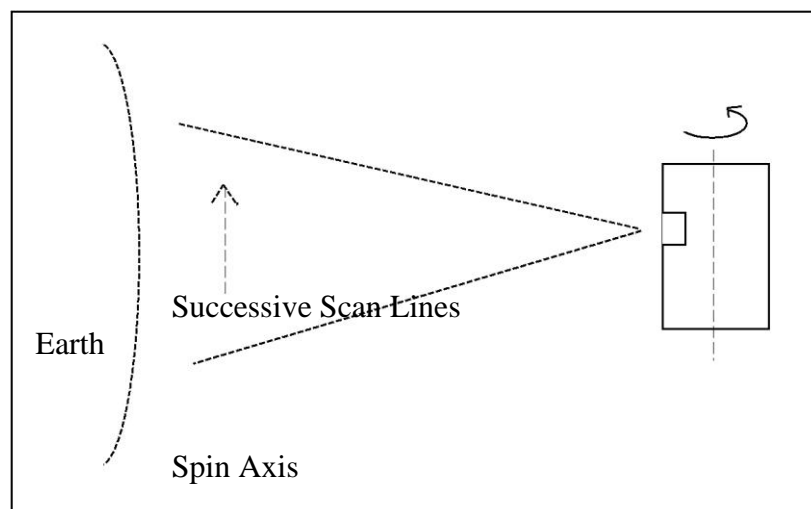

Figure 3.1 Image Acquisition

Each time the satellite rotates, the radiation detectors for the various channels pan across the earth ‘horizontally’ from east to west, acquiring one line of data. Between each rotation, a stepping tilt mirror in the camera optics adjusts position so that the next acquired line is offset ‘vertically’ (i.e. northwards) from the last. At 100 rpm spin speed, 100 lines are acquired per minute and a total image is acquired every 25 minutes (2500 scan lines). A five-minute retrace and stand-by period prepares the satellite for the start of the next image from the southern horizon, so that the image interval is 30 minutes. This interval is known as a *slot*, and there are 48 slots in each day of operations. Slots are numbered from midnight so that slot 1 covers data acquired from midnight to 00:30 UTC, slot 2 from 00:30 UTC to 01:00 UTC, and so on up to slot 48 (23:30 UTC to midnight).

Emissions in the following three spectral wavebands are detected by Meteosat:

VIS wavelengths in the range 0.5 to 0.9 microns - showing reflected light in the *visible* part of the spectrum.

IR wavelengths in the range 10.5 to 12.5 microns - showing emitted radiation in the thermal *infrared* part of the spectrum.

WV wavelengths in the range 5.7 to 7.1 microns - showing radiation from one of the *water vapour* absorption bands of the spectrum.

Data are acquired at two resolutions. In the Water Vapour (WV) and Infrared (IR) channels, 2500 pixels are acquired in each scan line, so that a complete image consists of 2500 x 2500 pixels. This gives a spatial resolution of approximately 5 km at the sub-satellite point. In the Visible (VIS) band, data are acquired at twice this resolution. As the spin speed of the satellite is fixed, this requires two detectors, one positioned above the other, so that two lines are acquired on each rotation. The VIS detectors have half the field of view of the WV and IR detectors, and read out twice as fast, so that 5000 pixels are acquired in each scan line. The output from the satellite in VIS therefore consists of two images, one from the northern detector (VIS_N) and one from the southern detector (VIS_S), each of which contains 2500 lines of 5000 pixels. By interleaving the lines from the two detectors, a full Visible composite image of 5000 lines of 5000 pixels can be constructed. This gives a resolution of approximately 2.5 km at the sub-satellite point.

Within the archive, image data are always aggregated so that data from a single 30-minute slot is held in a single file. Depending on the operational mode and the age of the data, not all channels may be present in a given image file. In particular, the older satellites could not support concurrent acquisition from all channels during a slot, so the WV channel and one VIS channel were operated alternately. The most recent satellites do not have this restriction, and in general all image channels are therefore now present for all slots.

For the purposes of retrieval, each image channel is treated as a separate orderable product. There are therefore five available image products:

- IR image;
- WV image;
- VIS_N image;

- VIS_S image;
- VIS (composite) image.

Image data can be supplied for any or all of these spectral channels and for the full earth disc or for any smaller geographical area. Image data may be requested as rectified or raw (i.e. un-rectified). It should be noted that for all quantitative applications rectified data are necessary and, in addition, for optimum visual quality (as well as for best use when animating multiple images) rectified data are also recommended.

3.2 Basic Image Navigation

This section provides a brief introduction to image navigation. It explains how different points on the image are identified and referenced.

Each image consists of series of *lines* made up of individual *pixels*. The number of lines and the number of pixels in a given image product vary according to the channel and the geographical area selected, as described above.

Lines and pixels are counted from 1 upwards, starting at the point where the scan starts. Because the scan starts at the bottom of the image (see Figure 3.1), this means that line 1 is the southernmost line, and pixel 1 is the easternmost pixel.

In rectified images of the full earth disc rectified the equator is located between the middle pair of lines in the image (e.g. between lines 1250 and 1251 for IR or WV channels, or between lines 2500 and 2501 for VIS composite). Similarly, the central longitude meridian is located between the middle pair of pixels.

3.3 Product Sizing

The following table summarises the size, production rate and total daily volume of each available full earth disc, full resolution image product for a single satellite.

Product	Unit Size (Kbytes)	Daily Products	Daily Volume (Mbytes)
VIS	25000	48	1200
VIS_S	12500	48	600
VIS_N	12500	48	600
IR	6250	48	300
WV	6250	48	300

4 INTRODUCTION TO METEOROLOGICAL PRODUCTS

4.1 Overview

Meteorological products are generated from the Meteosat image data at regular intervals, and contain derived geophysical parameters. Eleven products are currently stored in the Meteosat archive, these are as follows:

- Cloud Analysis (CLA);
- Cloud Motion Winds (CMW);
- Sea Surface Temperatures (SST);
- Upper Tropospheric Humidity (UTH);
- Climate Data Set (CDS);
- ISCCP Data Sets (IDS) – B1 and B2 formats;
- High Resolution Visible Winds (HRV);
- Expanded Low-resolution Winds (ELW);
- Clear-sky Water Vapour Winds (WVW);
- Clear Sky Radiances (CSR);
- High Resolution Water Vapour Winds (HWW).

Of these products, CLA, CMW, SST, UTH, HRV, ELW, WVW, CSR, and HWW are produced by EUMETSAT for dissemination to end-users on the Global Telecommunication System (GTS) through which world-wide meteorological agencies exchange data.

The other two products (CDS and IDS) are not disseminated via the GTS, but are ingested into the Archive and for the IDS products, for non-real-time distribution according to international agreements. Although these products are mainly produced for international co-operative programmes, they are available to all end-users via the Data Centre Online Ordering Application (<http://archive.eumetsat.int>).

Except for the IDS data, which are comprised of various extracts of the raw imagery, all of these products are derived on the basis of processing image segments. These segments represent groups of image pixels, which are considered as a block for the purposes of product generation.

The segmentation process, which precedes product extraction, divides the rectified earth image into areas of 32 x 32 infrared pixels. This approach provides a ground resolution of approximately 160 km at the sub-satellite point for the retrieved parameters. An 80 x 80 matrix of segments covers the complete Meteosat field of view, space included. In practice, processing for product extraction is limited to approximately 3850 segments within a 60° great circle arc of the sub-satellite point. (Beyond this limit, the viewing geometry distorts the imagery and reduces data quality so that product retrieval is not worthwhile.)

Each product (except IDS) contains a set of data points, each generally relating to one of the image segments described above. In practice, most products do not contain a data point corresponding to every segment, either because the data are only relevant to segments corresponding to sea, or are dependent on the percentage cloud cover.

The segment concept is illustrated in Figure 4.1.

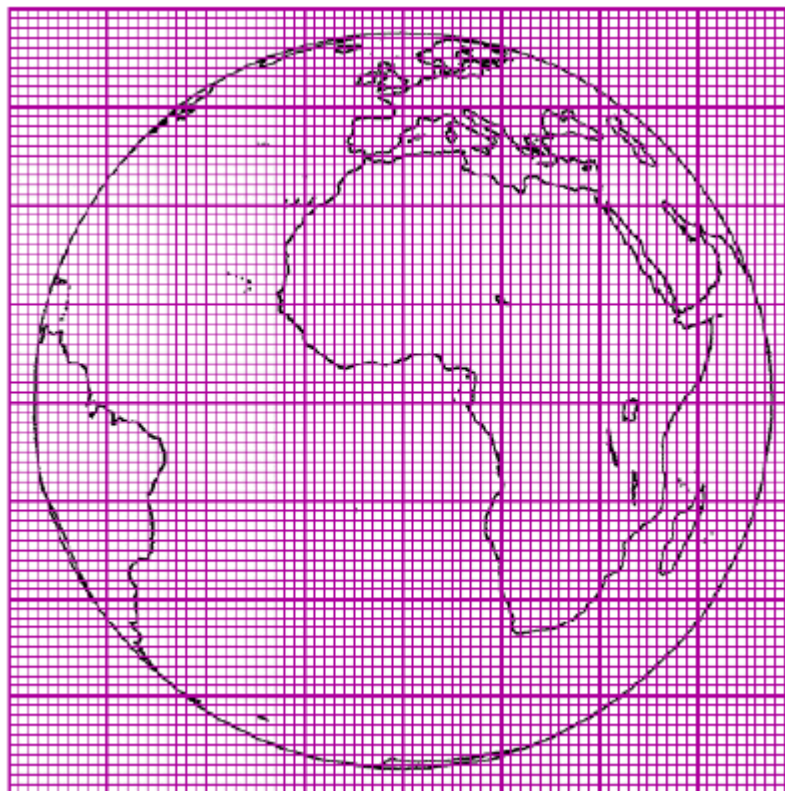

Figure 4.1 Image Segmentation for Product Extraction

The specific characteristics of each type of product are summarised in the following subsections. Product generation frequency has varied with time, albeit with most generation times being close to conventional synoptic observing times.

Cloud Analysis (CLA)

The Cloud Analysis product estimates cloud cover and cloud top temperature in each segment. Up to three different cloud layers can be identified. For each segment, the percentage cloud cover of each layer is stored, together with the cloud top temperature.

Cloud Motion Winds (CMW)

The Cloud Motion Winds product is generated by applying correlation algorithms to sequences of images. By tracking the movement of cloud masses, winds can be derived. Heights are assigned to the winds by relating the cloud temperature to forecast atmospheric temperature profiles.

Sea Surface Temperatures (SST)

One temperature is generated for each segment where the sea is visible from geostationary orbit. This excludes land segments and those with continuous cloud cover during the period of observation.

Upper Tropospheric Humidity (UTH)

The Upper Tropospheric Humidity product contains an estimate of the level of water vapour in the troposphere. In addition, since December 1997, this product has also contained a measurement of the clear sky water vapour radiance where no medium or high clouds are present.

Climate Data Set (CDS)

The CDS product contains a condensed form of the information contained in the raw image segments. The mean pixel count, the standard deviation and the number of pixels in detected pixel clusters are given. These clusters correspond to discrete scenes (clouds or earth surface) within the segment. The product also includes the IR mean pixel count of the clusters corrected for atmospheric absorption effects and, in the case of high clouds that do not appear opaque to the IR sensor, also corrected for semi-transparency.

ISCCP Data Sets (IDS)

The IDS products are generated as part of EUMETSAT's contribution to the International Satellite Cloud Climatology Project (ISCCP) of the World Climate Research Programme (WCRP) of the WMO, but are available to all users. They consist of full disc coverage of raw image data sub-sampled to reduced resolution.

B1 data consist of 1:4 sub-sampled VIS and 1:2 sub-sampled IR & WV imagery, giving a sub-satellite point ground resolution of ca. 10 km. B2 data consist of 1:12 sub-sampled VIS and 1:6 sub-sampled IR & WV imagery, giving a sub-satellite point ground resolution of ca. 30 km.

High Resolution Visible Winds (HRV)

The High Resolution Visible Winds product is generated using essentially the same algorithm as the CMW product, but applied to the VIS images in full resolution.

Expanded Low-resolution Winds (ELW)

The ELW product is generated from the same Intermediate CMW Product (see above), and consists of all winds from all channels with a QI greater than an AQC threshold considerably lower than the AQC threshold for the CMW product.

Clear-sky Water Vapour Winds (WWW)

The Clear-Sky Water Vapour Wind product is generated using essentially the same algorithm as the other wind products, but tracking structures in the WV image from non-cloudy areas.

Clear Sky Radiances (CSR)

The Clear Sky Radiances product contains an estimate of the mean WV channel brightness temperature from regions containing no or only low-level clouds.

High Resolution Water Vapour Winds (HWW)

The High Resolution Water Vapour Wind product is generated using essentially the same algorithm as the CMW product, but the WV images are divided into sub-areas of 16x16 pixels, i.e. the same resolution as the HRV product.

4.2 Product Sizing

Product sizes vary considerably from product to product and often from slot to slot. Additionally, format and algorithm changes over the years have often resulted in major changes in product size. Currently, these sizes range from ca. 250 Kbytes (for SST) up to ca. 4500 Kbytes (for the IDS B1 product).

5 DATA GEOLOCATION AND GEOCODING

5.1 Introduction

This section explains how to navigate Meteosat images. Specifically, it addresses geo-location (how to translate positions of image pixels into 'real world' positions, e.g. latitudes and longitudes) and geo-coding (how to transform the data into different map formats).

Section 5.2 explains how to navigate image data. Section 5.3 explains how to navigate meteorological product data. The explanations include both theoretical discussions and listings of example software.

5.2 Image Data Navigation

All MFG image data sets supplied by the Data Centre Archive are presented in the form of rectangular arrays of pixels in a perspective projection (as seen by the satellite). Re-mapping to other projections, if required, is left for the user. The only geo-coding that is performed on the data (if requested) is rectification (see Section 3) which corrects the perspective image as seen to a nominal view, removing deformations due to changes in the spacecraft orbit and attitude and to irregularities in the spacecraft optics and sensor behaviour.

This section explains how to navigate an image by converting between geographical (latitude and longitude) and digital (line and pixel) co-ordinates, in either direction. It is divided into four parts:

- Section 5.2.1 introduces the basic terminology associated with the viewing geometry, along with key formulae;
- Section 5.2.2 introduces the concepts associated with digital (line and pixel) co-ordinates;
- Section 5.2.3 describes the conversion from geographic to digital co-ordinates;
- Section 5.2.4 describes the conversion from digital to geographic co-ordinates.

Each of the latter two sections is divided into a theoretical part, showing how the conversion is derived, and a software part containing an example implementation of the conversion.

The following general assumptions are applied throughout:

1. All areas are defined relative to a *rectified reference image*. Users may apply the conversions to un-rectified data but the results will contain a certain degree of error.
2. Absolute longitudes are measured eastwards from Greenwich, with a range -180° to $+180^{\circ}$ (i.e. increasing to the East).

3. Latitudes are measured north from the Equator, with a range -90° to $+90^\circ$ (i.e. increasing to the North). It should however be noted that the maximum latitude visible from a geostationary equatorial satellite is 81.27° .
4. The conversions are valid for satellites with nominal longitude between -90° and $+90^\circ$.

Line and pixel co-ordinates are determined as explained in Section 3.2.

5.2.1 Basic Terminology and Formulae

This section introduces the basic concepts needed to solve the problem of geographical to digital co-ordination conversion. It also provides a number of identities and formulae that are needed.

The basic geometry of the earth as seen from an equatorial geostationary satellite such as Meteosat is shown in Figure 5.1. In this geometry, the equator and the sub-spacecraft meridian define planes that pass through the satellite position. In consequence, these lines of latitude and longitude appear as straight lines in the perspective view (and hence on the image). In a rectified image, the equator lies along a single row of the image, and the sub-spacecraft meridian corresponds to a single column.

All other lines of latitude and longitude appear to bow outwards from these fixed central planes. This is a result of the satellite perspective.

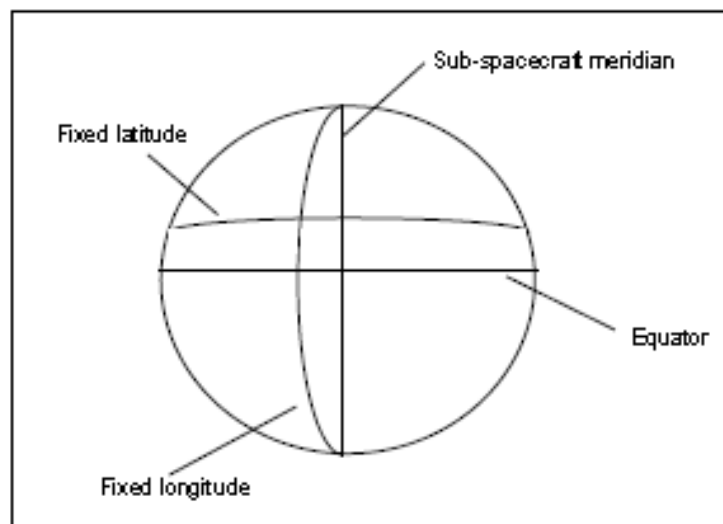

Figure 5.1 Spherical Geometry for an Equatorial Geostationary Satellite

To derive the conversions we require spherical and Cartesian co-ordinate systems. The spherical co-ordinate system is defined as follows:

- Origin at the centre of the earth;
- Geocentric Latitude θ_c , measured from the equator (positive to the north);
- Longitude ϕ , measured from the sub-spacecraft meridian (positive to the east);

- Radius r , the distance from the origin to a point.

The Cartesian co-ordinate system is defined as follows:

- Origin at the centre of the earth;
- x axis in the direction from the origin to the spacecraft;
- y axis to the right as seen from the spacecraft;
- z axis towards the top (north) as seen from the spacecraft.

Both systems are shown in Figure 5.2.

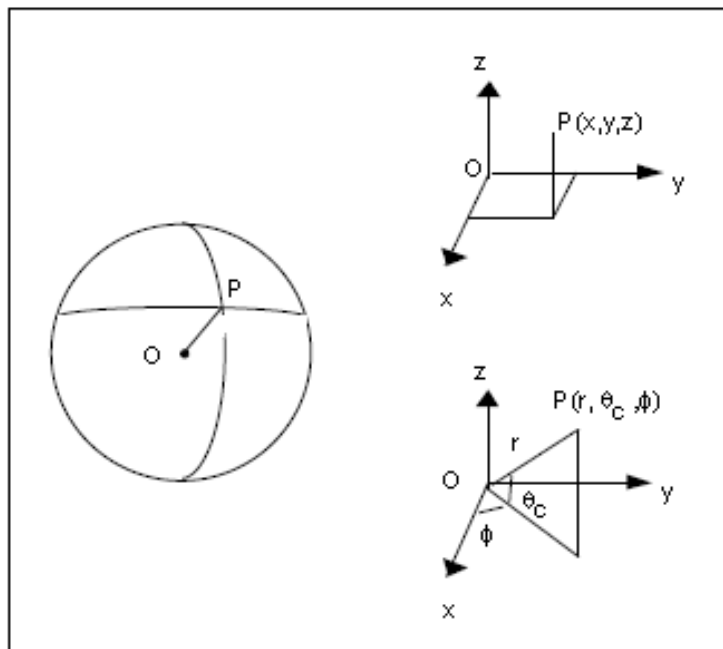

Figure 5.2 Co-ordinate Systems

The selection of an x -axis ($\phi = 0$) pointing to the satellite, and not to 0° (geographical) longitude is made because it greatly simplifies the subsequent calculations. The transformation between the ‘true’ longitude and the longitude in the selected co-ordinate system is trivial, as the apparent longitude is equal to the true longitude minus the nominal longitude of the satellite (e.g. a point at absolute longitude 10°E appears at 40°E when seen from a satellite at 30°W).

To simplify our particular problem, the approach taken is therefore to carry out the majority of the analysis in the reference system described above, and to perform a one-off transformation between this system and the absolute system at a convenient point.

Having defined the co-ordinate systems, the basic relationships can now be written down. Note that no approximations are made in the following analysis: characteristics such as the oblateness of the earth are fully taken into account throughout.

Transformation Between Co-ordinate Frames

$$x = r \cos \theta_c \cos \phi \quad y = r \cos \theta_c \sin \phi \quad z = r \sin \theta_c$$

Equatorial Radius of the earth $R_e = 6378.140 \text{ km}$

Polar Radius of the earth $R_p = 6356.755 \text{ km}$

Oblateness of the earth $f = (R_e - R_p) / R_e = 1/298.257$

Co-ordinates of the Satellite: Cartesian Frame

$(R_s, 0, 0)$ where R_s is the distance from the origin to the satellite = 42164.0 km

One additional transformation is needed, between geocentric and geodetic latitudes. The relationship between these latitudes is shown in Figure 5.3.

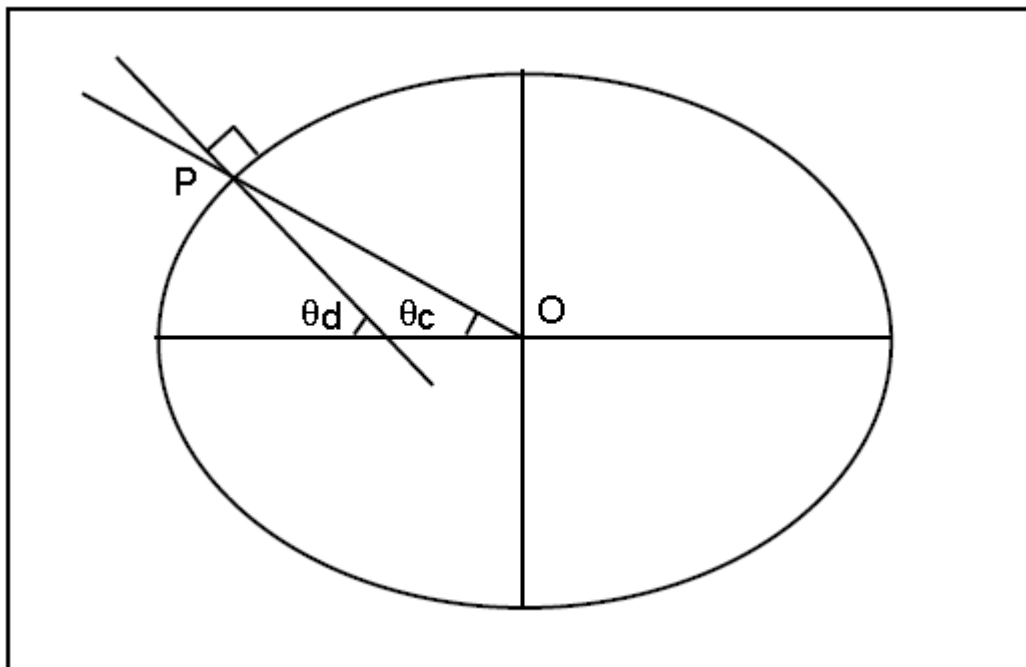

Figure 5.3 Geocentric and Geodetic Latitudes

For a point P on the surface of the earth, the geocentric latitude θ_c is the angle between OP and the equatorial plane. The geodetic latitude θ_d is the angle between the local normal at P and the equatorial plane. It is the geodetic latitude that corresponds to the normal geographic latitude that appears in an atlas.

The two latitudes are related by the following formula:

$$\tan \theta_d = \tan \theta_c / (1-f)^2$$

In the co-ordinate conversion software used below, calculations are generally performed using the geocentric latitude because this simplifies the algorithms. Conversions to and from the geodetic latitude are performed where necessary to enable the data to be input from or presented to the user in the normal way.

Distance from the Centre to the Surface of the Earth at a Given Latitude

The most difficult aspect in dealing with an accurate model for the earth, i.e. one where the earth is actually oblate rather than spherical, is that the distance to the surface (r in the spherical co-ordinates) is a function of latitude.

The earth's surface can be expressed as: $(x^2 + y^2) / R_e^2 + z^2 / R_p^2 = 1$
 substituting the spherical co-ordinates:

$$((r \cos \theta_c \cos \phi)^2 + (r \cos \theta_c \sin \phi)^2) / R_e^2 + (r \sin \theta_c)^2 / R_p^2 = 1$$

which reduces to:

$$r = R_e R_p / \sqrt{R_p^2 \cos^2 \theta_c + R_e^2 \sin^2 \theta_c}$$

This distance will be referred to in what follows as r_θ .

Local Normal at the Point

For a point $P(x, y, z)$, the vector OP has components (x, y, z) . The vector of the local normal at the surface would have the same components in the case of a spherical earth, but for an oblate earth it has components $(x, y, z(R_e^2/R_p^2))$.

5.2.2 Digital Coordinate Geometry

Section 3.1 described how the spinning Meteosat satellite acquires data on a line by line basis. This section shows how the line and pixel co-ordinates are related to the viewing geometry described in Section 5.2.1.

Starting with the line co-ordinate, each line of data is gathered with the tilt mirror fixed at a constant angle with respect to the spin axis of the satellite. This means that each line corresponds to a cone swept out in space, as shown in Figure 5.4. For the middle line (1250), the mirror sweeps around the equatorial plane. For other lines (e.g. line 2000), the mirror is tilted out of this plane.

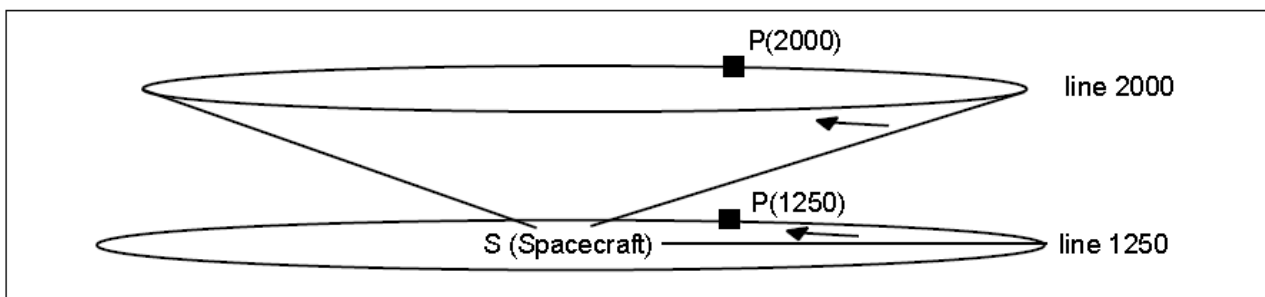

Each successive line is gathered by tilting the mirror by one additional step, with each step corresponding to a fixed angular increment. The number of lines between a point P and the middle line of the image is therefore easily calculated by dividing the angle between SP and the equatorial plane by this angular increment.

For the pixel direction, each pixel in a line represents a fixed fraction of the total cone swept out by that line. It is also apparent that the equivalent pixels on successive lines are exactly aligned vertically as seen from the spacecraft.

Directly calculating a pixel number in terms of the angle swept around the cone is complex, except for the middle line where the geometry is two-dimensional. For the pixel number, we therefore take advantage of the fact that the pixel number of a point in any line (e.g. P(2000) in Figure 5.4 above) is identical to the pixel number of the equivalent point in the middle line (i.e. P(1250)) directly below.

From this discussion, it is also easy to create an appropriate paradigm for visualising the line/pixel geometry. A classic way to visualise a raster image geometry is as a grid suspended in front of the camera. For Meteosat, this grid should be thought of as cylindrical to provide the correct behaviour of lines and pixels as illustrated in Figure 5.5 below.

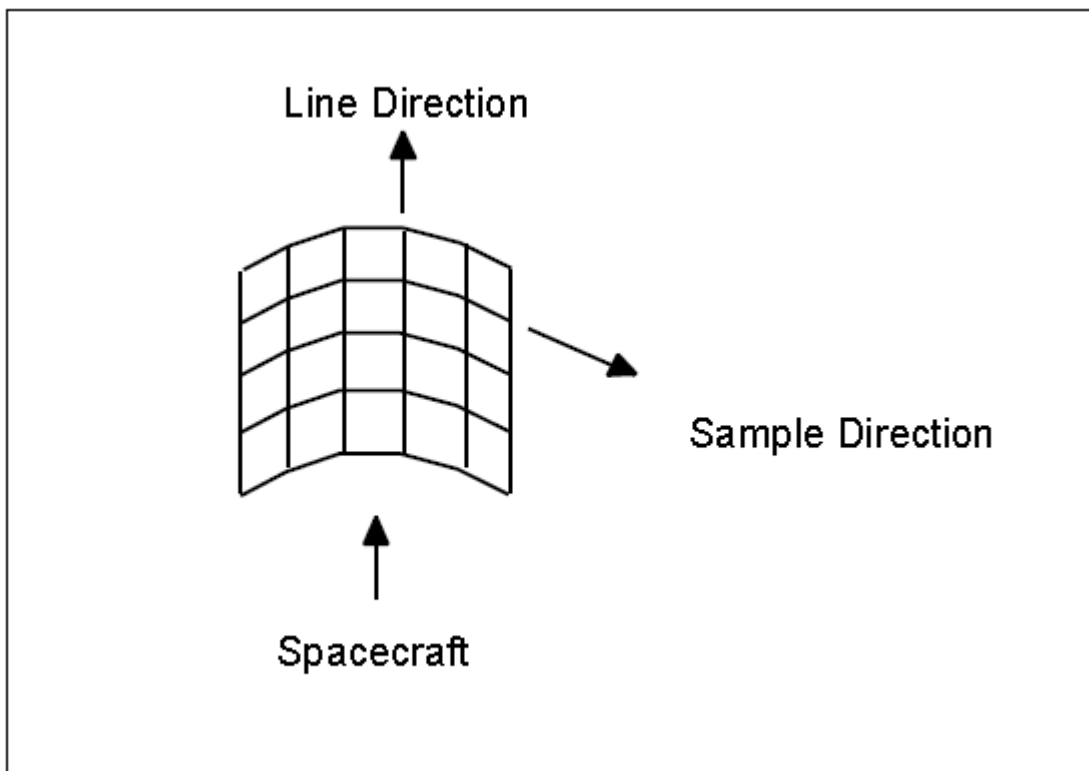

Figure 5.5 Line/Pixel Geometry

5.2.3 Point Conversion (Geographic to Digital)

5.2.3.1 Theory

This section addresses the way in which a single point's geographical co-ordinates (latitude, longitude) can be transformed into digital co-ordinates (line, pixel) as seen from Meteosat. It also provides a visibility test to determine whether the point can be seen from the spacecraft.

The point of interest is defined as $P(\theta_d, \phi)$. (The r is ignored by convention since the point is pre-defined to be on the earth's surface.) Starting from these co-ordinates, the line and pixel position are calculated as follows.

1. Convert θ_d to θ_c
2. Calculate r_θ for the given latitude.
3. Calculate the Cartesian co-ordinates of $P(x,y,z)$ using the transformation between co-ordinate frames given in Section 5.2.1.
4. Drop a perpendicular from P onto the equatorial plane to form point O' . This is shown in Figure 5.6.
5. Calculate the angle PSO' and divide this by the line direction angular step to calculate the line number of the point.
6. Calculate the angle $O'SO$ and divide this by the pixel direction angular step to calculate the pixel number of the point. (This works because the pixel number of point O' must be the same as that of point P , as discussed above.).

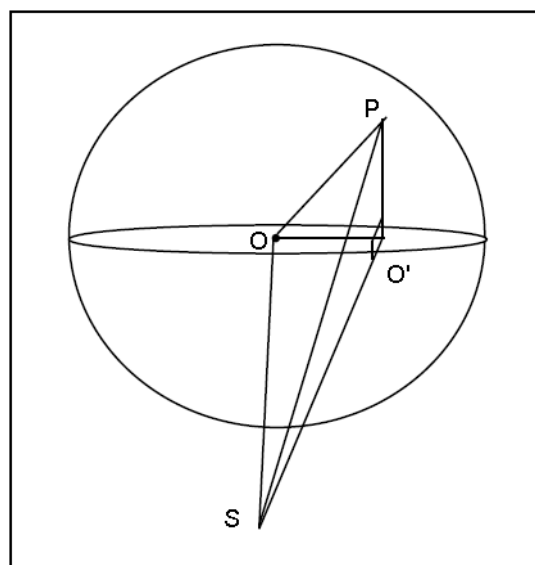

Figure 5.6 Determining the Angular Position of a Point

The angular step for any channel is equal to 18° (the Meteosat field of view) divided by the total number of lines or pixels in that channel as appropriate. The angle PSO' can be calculated by simple trigonometry, since the construction of O' ensured that the triangle PSO' is right-angled.

The co-ordinates of the three points in this triangle are:

P - (x, y, z)

S - (R_s, 0, 0)

O' - (x, y, 0)

Hence:

$$\tan(\text{angle PSO}') = O'P / O'S = z / \sqrt{(y^2 + (R_s - x)^2)}$$

For the pixel co-ordinate, the equivalent calculation is:

$$\tan(\text{angle O'SO}) = OO' / OS = y / (R_s - x)$$

The visibility test for any point P is based on the fact that the dot product of two vectors A and B has a value of |A||B| cos α where α is the angle between them. Since the horizon line as seen from the spacecraft is defined as the locus of points where the local normal is perpendicular to the line to the spacecraft, all visible points have angles of less than 90° between the local normal vector and the vector to the spacecraft. All invisible points similarly have angles of more than 90° between these two vectors.

To determine whether a point P (x, y, z) is visible, one simply takes the local normal vector (see Section 5.2.1) and the vector to the spacecraft (R_s-x, -y, -z), and examines the sign of the dot product. If the sign is negative the point is invisible.

5.2.3.2 Software

N.B. This section contains example Fortran subroutines provided to give guidance for possible implementations of the theory described above. Users should take note, however, that EUMETSAT cannot guarantee the accuracy of this software.

A listing of an example program to perform the geographical to digital conversion is given below. Note that this subroutine assumes the satellite is positioned above 0° longitude, and also that it only applies to IR and WV images. For visible images the different line and pixel resolutions need to be allowed for.

subroutine georef (rlat, rlong, line, pixel, visible)

C This subroutine converts pixel position from geographical
C (lat / long) co-ordinates to digital (line / pixel) co-ordinates.

C Input parameters:

C rlat - latitude of pixel (North is +ve, South is -ve)

C rlong - longitude of pixel (East is +ve, West is -ve)

C Note that these are standard geographic co-ordinates as would

C be found in an atlas.

C Output parameters

C line - line number, measured from southern end of frame

C pixel - pixel number, measured from eastern end of frame

C visible - flag set to TRUE if pixel is on visible disc,

C - flag set to FALSE if pixel is in space.

C (c) EUMETSAT 1997

implicit none

real*4 rlat, rlong, lat, long, geolat

real*4 altitude, req, rpol, oblate, pi, deg_to_rad, rad_to_deg

real*4 x, y, z, rtheta, aline, asamp, dotprod

integer*4 line, pixel, nlines, nsamps

logical*1 visible

C Set up constants.

C altitude = distance from earth centre to satellite

C req = Equatorial earth radius

C rpol = Polar earth radius

C oblate = earth oblateness

C deg_to_rad and rad_to_deg are conversion factors

altitude = 42164.0

req = 6378.140

rpol = 6356.755

oblate = 1.0 / 298.257

pi = 3.141592653

deg_to_rad = pi / 180.0

rad_to_deg = 180.0 / pi

C Convert inputs to radians

geolat = rlat * deg_to_rad

long = rlong * deg_to_rad

**C Convert geodetic latitudes (as input) to geocentric latitudes
C for use within the algorithm**

$$\text{lat} = \text{atan} (((1.0 - \text{oblate}) **2) * \tan (\text{geolat}))$$

**C Calculate rtheta. This is the distance from the earth centre to
C a point on the surface at latitude 'lat'.**

$$\text{rtheta} = (\text{req} * \text{rpol}) / \text{sqrt} (\text{rpol} **2 * \cos(\text{lat}) **2 + \text{req} **2 * \sin(\text{lat}) **2)$$

**C Calculate Cartesian co-ordinates of target point. This is
C basic geometry. The co-ordinate system is geocentric with
C the x-axis towards the spacecraft, the y-axis to the East
C and the z-axis towards the N pole.**

$$\begin{aligned}x &= \text{rtheta} * \cos(\text{lat}) * \cos(\text{long}) \\y &= \text{rtheta} * \cos(\text{lat}) * \sin(\text{long}) \\z &= \text{rtheta} * \sin(\text{lat})\end{aligned}$$

**C Check for invisibility. This is done using the basic geometric
C theorem that the dot product of two vectors A and B is equal
C to**

$$|A||B| \cos (\text{theta})$$

**C where theta is the angle between them. In this case, the test
C is simple. The horizon is defined as the locus of points where
C the local normal is perpendicular to the spacecraft sightline
C vector. All visible points have (theta) less than 90°
C and all invisible points have (theta) greater than 90°.**

**C The test therefore reduces to whether the sign of the dot
C product is +ve or -ve; if it is -ve the point is invisible.**

**C The vector from the point to the spacecraft has components
C Rs-x, -y, -z where Rs is the distance from the origin to the
C satellite. The vector for the normal has components**

$$x \ y \ z(\text{Re}/\text{Rp})^2$$

$$\text{dotprod} = (\text{altitude}-x) * x - y * y - z * z * ((\text{req}/\text{rpol}) **2)$$

if (dotprod .le. 0.) then

visible = .false. line = 0

pixel = 0 goto 999

else

visible = .true.

endif

C In this co-ordinate system the spacecraft (S) is at position
C (altitude,0,0), the earth centre (O) at (0,0,0) and the point (P)
C at (x,y,z). Two additional points need to be defined, so that the
C angles from the reference planes to the target point (i.e. the
C position of the point in the sensor FOV) can be extracted.
C These points are defined by dropping lines perpendicularly from P
C onto the equatorial plane and the Greenwich meridian plane.
C Their co-ordinates are defined as:
C
C $O' = (x, y, 0)$ and $O'' = (x, 0, z)$.
C
C With these points, right-angled triangles can be defined SO'P
C and SO''P which can be used directly to determine the angular
C co-ordinates (aline, asamp) of P in the FOV.

asamp = atan (y / (altitude - x))
aline = atan (z / sqrt (y**2 + (altitude - x)**2))

C Convert back to degrees

asamp = asamp * rad_to_deg
aline = aline * rad_to_deg

C Calculate line, pixel. Note that since pixels are measured from
C the right of the image, and the angular conversion was measured in
C the x (east) direction, a sign correction has to be included for
C pixels. The image represents an 18° x 18° field of view
C divided up on an equi-angular basis.

nlines = 2500
nsamps = 2500
asamp = asamp / (18.0 / float(nsamps))
aline = aline / (18.0 / float(nlines))

```
if (asamp .ge. 0.0) then
  pixel = nsamps / 2 - int (asamp)
else
  pixel = nsamps / 2 + 1 - int (asamp)
endif
```

```
if (aline .ge. 0.0) then
  line = nlines / 2 + 1 + int (aline)
else
  line = nlines / 2 + int (aline)
endif
```

```
999 continue
return
end
```

5.2.4 Point Conversion (Digital to Geographic)

5.2.4.1 Theory

This section explains how to convert digital to geographic co-ordinates on a point basis. The same co-ordinate frames and definitions are used here as in Section 5.2.3. The basis of the algorithm is a determination of the intersection point between the surface of the earth and the viewing line from the spacecraft.

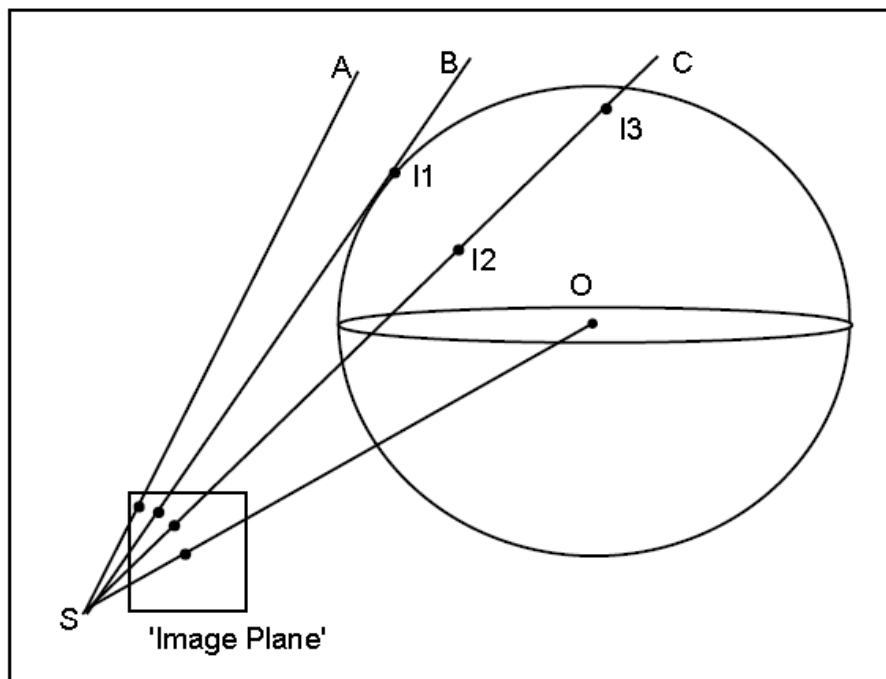

Figure 5.7 Viewing Lines from the Spacecraft

There are three possibilities for this intersection. There can be no intersections (line A), one intersection (line B - the intersection point I1 just clips the edge of the disc) or two intersections (line C - the intersection points I2 and I3 pass through the front/visible and back/invisible sides of the disc).

The viewing lines can be thought of in terms of lines drawn from an origin at the spacecraft through an 'image plane' in front of the spacecraft. To determine the intersection point(s), equations must be defined for the viewing line and the earth's surface.

The equation of the viewing line can be defined in vector terms as:

$$OS + k \cdot SP$$

where OS is the vector from the origin to the spacecraft, k is a scalar variable, and SP is a vector of any size defining the direction from the spacecraft towards the viewed point. Varying k then defines the locus of all points on the line.

The vector OS has co-ordinates $(R_s, 0, 0)$ as per Section 5.2.3.

The vector SP can be determined from the line and pixel co-ordinates of the point in the image. As per Section 5.2.3, these co-ordinates are directly related to the angular offset of the viewing line from the equator and the sub-spacecraft meridian.

Assume that the vector SP has co-ordinates $(p \ q \ r)$. The geometry of Figure 5.7, and the calculations in Section 5.2.3, can be applied to define the angles in the line (α_L) and pixel (α_S) directions as follows:

$$\tan(\alpha_L) = r / \sqrt{p^2 + q^2} \quad (1) \text{ and}$$

$$\tan(\alpha_S) = q / p \quad (2)$$

Assuming for convenience that $p = 1$ (as noted above, the vector does not need to be normalised as k takes account of any scaling), the second equation transforms to:

$$q = \tan(\alpha_S)$$

and the first becomes:

$$r = \tan(\alpha_L) \sqrt{1 + q^2}$$

The line and pixel co-ordinates are directly related to the angles α_L and α_S as the image steps a constant angle for each line and pixel.

The intersection points between the viewing line and the earth are defined by

$$OS + k \cdot SP = OP \quad \text{where } OP \text{ is the earth surface.}$$

Taking the Cartesian components:

$$(R_s) \quad \quad \quad (p) \quad \quad \quad (x)$$

$$(0) \quad + \quad k \quad (q) \quad = \quad (y)$$

$$(0) \quad \quad \quad (r) \quad \quad \quad (z)$$

$$\text{i.e. } x = R_s + pk$$

$$y = qk$$

$$z = rk \quad (3)$$

However, from Section 3,

$$(x^2 + y^2) / R_e^2 + z^2 / R_p^2 = 1$$

and substituting for x , y and z , this becomes:

$$k^2 (p^2 + q^2 + r^2 \cdot R_e^2 / R_p^2) + k (2 R_s p) + (R_s^2 - R_e^2) = 0$$

This can be solved as a standard quadratic equation ($ax^2 + bx + c = 0$). If there are no real roots, there are no intersections. If both roots are the same there is one intersection. If there are two real roots there are two intersections.

To obtain the geodetic co-ordinates of the viewed point, the following algorithm can therefore be applied.

1. Calculate viewing angles from the line/pixel co-ordinates.
2. Calculate viewing vector co-ordinates p, q, r.
3. Determine roots of k.
4. If there are any real roots, take the smaller one (this will be the 'front' or visible intersection).
5. Substitute the value of k back into (3) to obtain (x, y, z).
6. Convert to polar co-ordinates to obtain latitude and longitude of the point.
7. Convert geocentric (working) latitude to geodetic latitude for output.

5.2.4.2 Software

N.B. This section contains example Fortran subroutines provided to give guidance for possible implementations of the theory described above. Users should take note, however, that EUMETSAT cannot guarantee the accuracy of this software.

A listing of an example program to perform the digital to geographical conversion is given below. Note that this subroutine assumes the satellite is positioned above 0° longitude, and also that it only applies to IR and WV images. For visible images, the different line and pixel resolutions need to be allowed for.

subroutine refgeo (line, pixel, lat, long, visible)

C This subroutine converts digital to geographical co-ordinates.

C Input parameters:

C line - line number, measured from southern end of frame

C pixel - pixel number, measured from eastern end of frame

C Line and pixel values are real numbers to enable sub-pixel

C accuracy. Integer values correspond to the middle of the pixel,

C e.g.(500, 800) would correspond to the middle of the pixel with

C corners (499.5, 799.5), (499.5, 800.5), (500.5, 799.5), (500.5, 800.5).

C Output parameters

C lat - latitude of this pixel (degrees North from Equator)

C long - longitude of this pixel (degrees East from Greenwich)

C visible - flag set to TRUE if pixel is on visible disc,

C - flag set to FALSE if pixel is in space.

C (c) EUMETSAT 1997

implicit none

real*4 lat, long, line, pixel, cenlat

real*4 aline, asamp, tanal, tanas, det, k

real*4 altitude, req, rpol, oblate, pi, deg_to_rad, rad_to_deg

real*4 step, x, y, z, a, b, c, p, q, r

logical*1 visible

C Set up constants.

C altitude = distance from earth centre to satellite

C req = Equatorial earth radius

C rpol = Polar earth radius

C oblate = earth oblateness

C deg_to_rad and rad_to_deg are conversion factors

altitude = 42164.0

req = 6378.140

rpol = 6356.755

oblate = 1.0 / 298.257

pi = 3.141592653

deg_to_rad = pi / 180.0

rad_to_deg = 180.0 / pi

C Step is the radiometer step as seen by the spacecraft,

C in degrees. The image represents an 18° x 18° field

C of view divided up on an equi-angular basis. For this

C program an IR channel of 2500 x 2500 is assumed but

C in the real code the size of each channel must be accounted C for.

step = 18.0 / 2500.0

C Convert line/pixel values to angular offsets from centre point

asamp = - (pixel - 1250.5) * step

aline = (line - 1250.5) * step

asamp = asamp * deg_to_rad

aline = aline * deg_to_rad

C Calculate tangents of angles

tanal = tan(aline)

tanas = tan(asamp)

C Calculate components of an arbitrary vector from the spacecraft

C in the viewing direction.

p = -1.

q = tanas

$$r = \tan \alpha * \sqrt{1 + q * q}$$

C The location of the point on the earth can be identified by
C solving a quadratic equation for the intersection between
C the earth's surface and the viewing line from the spacecraft.
C If this equation has no real roots then there is no intersection;
C otherwise the required root is the one nearer to the spacecraft
C (on the visible side of the earth).

$$a = q * q + (r * r_{eq} / r_{pol}) ** 2 + p * p$$
$$b = 2 * \text{altitude} * p$$
$$c = \text{altitude} * \text{altitude} - r_{eq} * r_{eq}$$

C Calculate determinant. If it is negative (no real roots to
C quadratic equation) there is no intersection between the
C line of sight and the disc and so the pixel does not correspond
C to visible data.

$$\text{det} = b * b - 4 * a * c$$

if (det .le. 0.) **then**

visible = .false.

lat = 0.

long = 0.

goto 999

else

visible = .true.

endif

$$k = (- b - \sqrt{\text{det}}) / (2 * a)$$

$$x = \text{altitude} + k * p$$

$$y = k * q$$

$$z = k * r$$

$$\text{long} = \text{atan}(y/x)$$

$$\text{cenlat} = \text{atan}(z * \cos(\text{long}) / x)$$

C This is the geocentric latitude. Convert it to the geodetic
C (or geographic) latitude before returning it to the calling program

$$\text{lat} = \text{atan}(\tan(\text{cenlat}) / ((1.0 - \text{oblate}) ** 2))$$

C Convert from radians to degrees

$$\text{lat} = \text{lat} * \text{rad_to_deg}$$

$$\text{long} = \text{long} * \text{rad_to_deg}$$

999 return

end

5.3 Meteorological Product Navigation

As described in Section 4.1, meteorological products are derived in general on a segment basis. The products consist of series of blocks that contain results for the individual segments, gathered over the whole area of the image that is considered geometrically suitable for product extraction.

The segments are organised into rows and columns, like the underlying pixels (see Figure 4.1). Each segment has a row/column location in the segment grid, measured from row 1, column 1 at the southeast corner. As each segment is 32 x 32 infrared pixels in size, it is relatively easy to calculate the line/pixel co-ordinates of the centre or corner of a segment, and this can readily be converted into latitude/longitude form using the transformations in Section 5.2 if required. In most cases this will not, however, be necessary, as most of the meteorological product formats already include latitude/longitude information for each segment for which data is provided.

As the meteorological products are relatively small, there is no need to support geographical sub-areas, and so each specific product is only available as a complete entity.

6 DIGITAL DATA DISTRIBUTION FORMATS

6.1 Introduction

This section describes the various formats that are used to distribute data to users in digital form.

6.2 File Formats

Image products are available in the following binary formats:

- OpenMTP
- McIDAS (area file format)

and three graphical formats as follows:

- GIF
- JPEG
- TIFF

Meteorological products are available in the following binary formats:

- OpenMTP
- BUFR

Note that for most meteorological products there is not a choice between these formats but rather it is defined per product. All data sets are available for order via the Data Centre Online Ordering Application (<http://archive.eumetsat.int>).

Apart from OpenMTP, which is described further below, the other formats are non-proprietary and intended for use with existing software packages. In the case of McIDAS format the software is the McIDAS processing package for which further details may be found on the web site of the University of Wisconsin at <http://www.ssec.wisc.edu/software/mcidas.html>. BUFR format is widely used in National Meteorological Services, it being a distribution format maintained by the World Meteorological Organisation (WMO). Further details of the BUFR format may be found at http://www.eumetsat.int/Home/Main/Access_to_Data/Meteosat_Meteorological_Products/BUFR_GRIB2/?l=en

OpenMTP format products contain data stored in open systems machine representation. Open systems machine representations are described in Appendix A.

The OpenMTP format is a customised 'scientific' data format. It incorporates not only the underlying image or product data but also much ancillary information. Special software is required to read these formats. The exact structure of each product in each format is described in the relevant *Format Guide* (see Section 1.2).

6.3 Delivery Methods

Data can be delivery either online or on media. Choosing the correct delivery method depends on the size of the order made. Online delivery is suitable for small orders and fast internet speeds on the client side. Media available for offline delivery can be found under the following URL:

http://www.eumetsat.int/Home/Main/Access_to_Data/Data_Centre/SP_1119424827079?l=en

7 IMAGE DATA PRINTS

The Data Centre Archive offers users the possibility of ordering image data in printed form.

Black and white and coloured printed images are produced using high quality graphics printers. As with the digital delivery, photographic products can be produced for any channel, for the full disc or any sub-area, and in rectified or un-rectified format.

The following photographic formats are available:

- A3 (31.5x46.5cm)
- A4 (31.5x25.5cm)

Coastline overlays are also available on request, as are latitude and longitude grids at varying resolutions. In addition users may specify customised captions. Further details are available from the EUMETSAT User Service Helpdesk (See Appendix B).

8 USING THE SERVICES

8.1 Introduction

This section provides more information on how to use the specific services offered by the Meteosat Archive. In all cases the User Service staff will be happy to provide more information and to discuss specific requirements. They can be contacted as described in Appendix B.

Users ordering data sets from the Data Centre Archive must agree to the EUMETSAT data policy. The latest version of this document can be found under the following URL:

http://www.eumetsat.int/Home/Main/AboutEUMETSAT/LegalInformation/SP_1228227333602?l=en

8.2 Requesting Documentation

Data Centre Documentation can be found under the following URL:

<http://www.eumetsat.int/Home/Main/Access to Data/Data Centre/index.htm?l=en>

Any enquiries related to the archive, documentation and its products and services, may be sent to the EUMETSAT User Service Helpdesk (See Appendix B).

8.3 Searching for Data

The Archive includes an extensive catalogue listing all available products. The catalogue can be queried using the Data Centre Online Order Application (<http://archive.eumetsat.int>). Description of the product collections can be found using the EUMETSAT Product Navigator (<http://navigator.eumetsat.int/>).

For MFG image data, these are available on a continuous half-hourly basis for all periods when Meteosat satellites were operational, i.e. from mid-1981 onwards. Some data are also available from the pre-operational satellite, covering the period November 1977 - November 1979, however these data sets are of relatively poor quality and are in any case only available for some dates and times. Customers wishing to obtain data from this earliest period should contact the EUMETSAT helpdesk to discuss their specific requirements.

Meteorological products are available on a regular basis throughout most of the operational periods. However, some products have been introduced during the mission (mainly in the first half of the 1980s), and in all cases the accuracy of the products has improved with time. Availability and quality is therefore reduced for the earlier years of operation.

8.4 Ordering Products

Products can be ordered via the Data Centre Online Order Application (<http://archive.eumetsat.int>). Users must register with the Archive via this application first before an order can be made. A user guide for this application and training slides can be found under the following URL:

http://www.eumetsat.int/Home/Main/Access_to_Data/Data_Centre/index.htm?l=en

APPENDIX A BINARY DATA OPEN SYSTEM REPRESENTATION

This appendix explains in detail how to decode binary data files distributed by the Meteosat Archive. This appendix explains the open system representation used in the OpenMTP file format. It describes the representation of the basic data types character, logical, short integer (two byte), integer (four byte), single-precision floating point numbers and double-precision floating point numbers.

The representation is 'big endian' which implies the following layout:

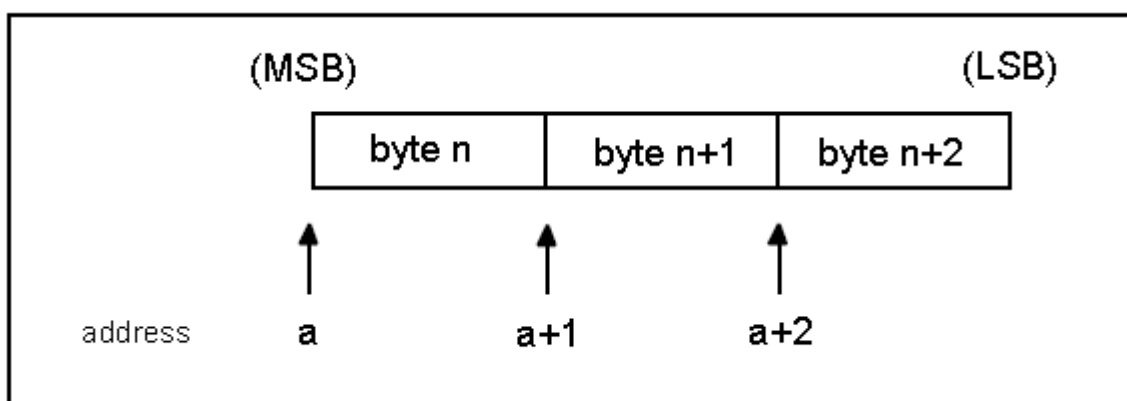

Byte n is more significant than byte n+1, i.e. the most significant byte is located at the lowest address, the least significant byte is located at the highest address. This is in contrast to 'little endian' format (employed by for instance DEC VAXs and IBM PCs) where the least significant byte is located at the smallest address and the most significant bytes are located at the highest address.

In the following, bytes will be numbered from left to right starting with 0. Also bits are numbered from left to right starting with 0. Thus in a two byte integer, for example, the left-most byte will be given the number 0, the right-most byte will be given the number 1, the left-most bit will be given the number 0 and the right-most bit will be given the number 15.

Character type

Character fields are coded in ASCII and occupy 1 byte of storage.

Logical type

Logical fields are coded in single bytes. A byte value of 0 corresponds to 'FALSE' and any other value to 'TRUE', although in line with convention a value of 1 is normally used for 'TRUE' within the OpenMTP format.

Short integer type

A short integer is two bytes in length. The short integer is represented in two's complement which means that bit 0 of byte 0 has negative weight ($-\text{bit } 0 * 2^{15}$). Unless otherwise stated, short integer fields should therefore be interpreted as signed values with a range of $-32768 \dots 32767$.

Integer type

A full integer is four bytes in length. It is represented in two's complement which means that bit 0 of byte 0 has negative weight ($-\text{bit } 0 * 2^{31}$).

Single-precision floating point

A single-precision (four byte) floating point number has the following representation:

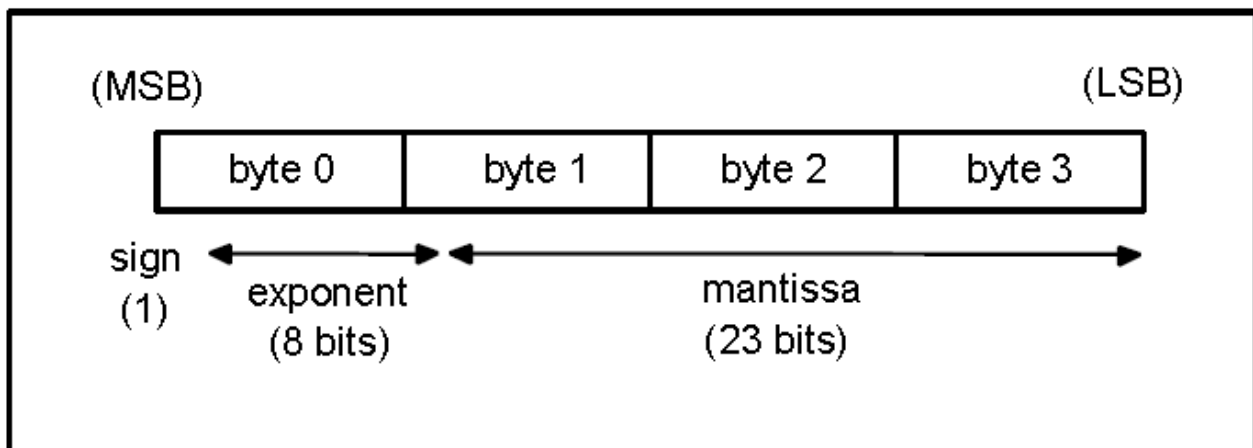

The following three fields describe the single-precision floating point:

- S: The sign of the number. Values 0 or 1 represent positive and negative respectively. One bit (bit 0) is devoted to this field.
- E: The exponent of the number, base 2. Eight bits are devoted to this field. The exponent is biased by 127. Thus the range of the exponent is -127 to 128 .
- M: The fractional part of the number's mantissa, base 2. Twenty-three bits are devoted to this field. The integer part of the mantissa is always a binary 1 for which reason it is implicit in the representation.

Double-precision floating point

A double-precision (eight byte) floating point number has the following representation:

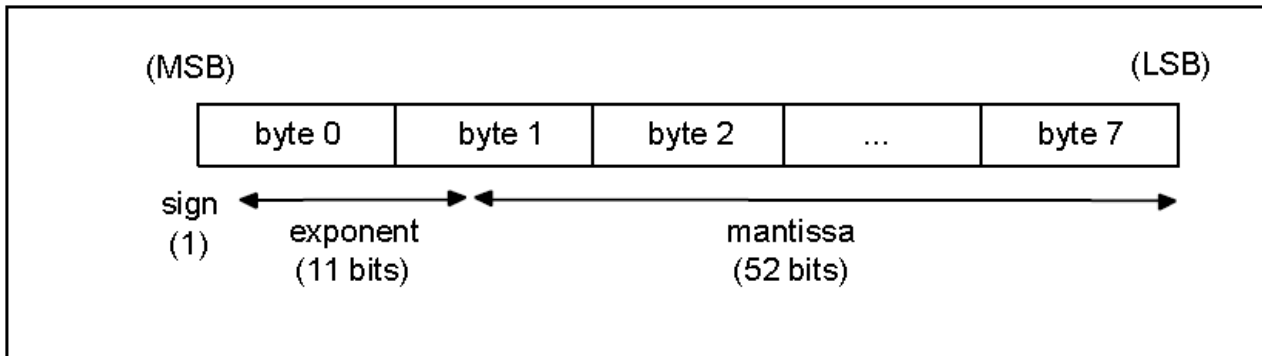

The following three fields describe the double-precision floating point:

- S: The sign of the number. Values 0 or 1 represent positive and negative respectively. One bit (bit 0) is devoted to this field.
- E: The exponent of the number, base 2. Eleven bits are devoted to this field. The exponent is biased by 1023. Thus the range of the exponent is -1023 to 1024.
- M: The fractional part of the number's mantissa, base 2. Fifty-two bits are devoted to this field. The integer part of the mantissa is always a binary 1 for which reason it is implicit in the representation.

APPENDIX B EUMETSAT User Service Help Desk

All EUMETSAT Data Centre Archive enquiries should be directed to:

**The User Service Help Desk
EUMETSAT
EUMETSAT Allee 1
64295 Darmstadt
GERMANY**

Tel: +49 6151 807 377

Fax: +49 6151 807 741

Email : ops@eumetsat.de

Archive URL: <http://archive.eumetsat.int>

Product Navigator URL: <http://navigator.eumetsat.int>

APPENDIX C ACRONYMS AND ABBREVIATIONS

ADC	Atlantic Data Coverage (mission of Meteosat-3 in support of GOES operation)
ASCII	American Standard Code for Information Interchange (also International Alphabet No. 5, standardised in ISO 646)
BGS	Back-up Ground Station (located in Cheia, Romania)
CCT	Computer Compatible Tape
CD-ROM	Compact Disc - Read Only Memory
CDS	Climate Data Set (meteorological product)
CF	Core Facility (part of EUMETSAT Mission Control Centre)
CLA	Cloud Analysis (meteorological product)
CMW	Cloud Motion Winds (meteorological product)
DAT	Digital Audio Tape
EBCDIC	Extended Binary Coded Decimal Interchange Code
ESOC	European Space Operations Centre (an ESA establishment located in Darmstadt, Germany)
EUMETSAT	European Organisation for the Exploitation of Meteorological Satellites
FOV	Field Of View
FTP	File Transfer Protocol
GIF	Graphics Interchange Format (a standard graphical format)
GOES	Geostationary Operational Environmental Satellite (USA)
GPCP	Global Precipitation Climatology Project (WMO)
GTS	Global Telecommunication System (of the WMO)
IDS	ISCCP Data Set (meteorological product)
INDOEX	Indian Ocean Experiment
IPS	Image Processing System (part of EUMETSAT Core Facility)
IR	Infrared (10.5 – 12.5 μ m ‘window’ radiation)
ISCCP	International Satellite Cloud Climatology Project (WMO)
ISO	International Standardization Organization
JPEG	Joint Photographic Experts Group (a standard “lossy” graphical format)
LSB	Least Significant Bit

MARF	Meteorological Archive and Retrieval Facility
MIEC	Meteorological Information Extraction Centre (ESOC facility now replaced by MPEF)
MOP	Meteosat Operational Programme (now replaced by MTP)
MPEF	Meteorological Products Extraction Facility
MSB	Most Significant Bit
MTP	Meteosat Transition Programme
NMS	National Meteorological Service
PDUS	Primary Data User Station (for receiving high resolution satellite images)
PGS	Primary Ground Station (located in Fucino, Italy)
SDUS	Secondary Data User Station (for receiving low resolution WEFAX satellite images)
SST	Sea Surface Temperature (meteorological product)
TIFF	Tagged Image File Format (a standard graphical format)
UTC	Universal Time Co-ordinated
UTH	Upper Tropospheric Humidity (meteorological product)
VIS	Visible (radiation within 0.5 – 0.9 μ m band)
WCRP	World Climate Research Programme (WMO)
WMO	World Meteorological Organization (UN)
WV	Water Vapour (5.7 – 7.1 μ m water vapour absorption band radiation)
WWW	World Weather Watch (WMO)
X-ADC	Extended Atlantic Data Coverage (mission of Meteosat-3 - see also ADC)