

# The SEVIRI Instrument

J. Schmid

ESA/ESTEC, Keplerlaan 1  
2200 AG Noordwijk  
The Netherlands.  
e-mail: jschmid@estec.esa.nl

## Abstract

The SEVIRI is a 50 cm diameter aperture, line by line scanning radiometer, which provides image data in four Visible and Near InfraRed (VNIR) channels and eight InfraRed (IR) channels. The VNIR channels include the High-Resolution Visible (HRV) channel, which contains 9 broadband detection elements to scan the Earth with a 1 km sampling distance at SSP. All the other channels (including the IR channels) are designed with 3 narrow band detection elements per channel, to scan the Earth with a 3 km sampling distance. The full Earth disc image is obtained after 1250 scan line steps (south – north direction) of 9 km SSP per line step. The satellite spin of 100 rpm allows to complete (east – west direction) a full image in about 12.5 min. A flip-flop mechanism is activated to put the on-board black body in the optical path for the instrument calibration. The black body is removed after about 2 seconds from the calibration position. After that, the scan mirror moves back to its initial position. The Earth observation is resumed (after retrace during ~2 min) leading to an overall repeat cycle of maximum 15 minutes.

The instrument functional architecture is based on four main assemblies:

- the Telescope and Scan Assembly (TSA) including the Calibration Unit and the Refocusing Mechanism,
- the Focal Plane & Cooler Assembly (FPCA),
- the Electrical Unit Assembly (EUA) consisting of the Functional Control Unit (FCU), the Detection Electronics (DE) including the Main Detection Unit (MDU), the Pre-amplifier Unit (PU) and the Detectors.

This paper will present the instrument design including a description of the SEVIRI hardware elements together with a summary of the flight unit performances.

## 1. Introduction

MSG is the new generation of geostationary, meteorological satellites developed by the European Space Agency (ESA) in close co-operation with the European Organisation for the Exploitation of Meteorological Satellites (EUMETSAT).

The satellite's main payload is the optical imaging radiometer so called Spinning Enhanced Visible and Infrared Imager (SEVIRI). Its 12 different spectral channels will provide 20 times more information than the current Meteosat satellites, offering new and, in some cases, unique capabilities

in cloud imaging and tracking, fog detection, measurement of the earth surface and cloud top temperatures, tracking ozone patterns, as well as many other improved performances. A new earth image will be provided every 15 minutes instead of every 30 minutes, as at present. The data circulation system will also be improved by allowing much higher data rates both for transmission (3.2 Mbps) and dissemination (1 Mbps). This, together with the enhanced imagery, will result in an important increase in capabilities for monitoring weather patterns over the Atlantic Ocean, Europe and Africa and for the prediction and warning of severe storms and other potentially hazardous phenomena like hurricanes. A detailed design description of the SEVIRI instrument can be found in Ref.1 and Ref.2.

This paper will present the MSG Optical Imaging Radiometer design and its performance as characterised through the flight model MSG-1 on-ground testing.

## 2. The SEVIRI Instrument Main Scope

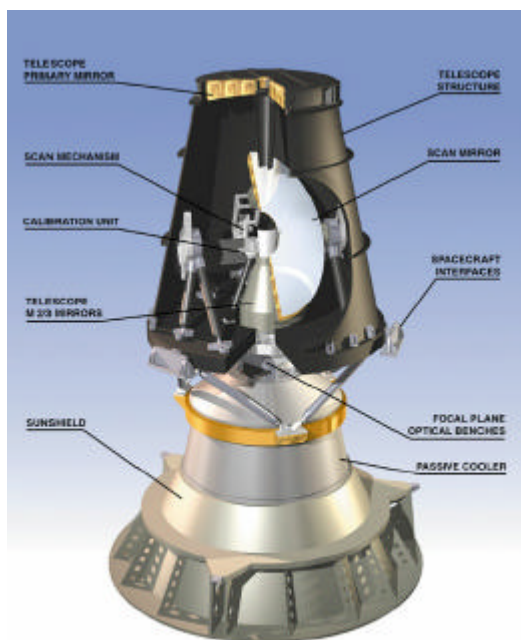

Fig. 1: SEVIRI Instrument Main Unit

SEVIRI Instrument Characteristics:

Spectral Range:

- 0.4 – 1.6 $\mu$ m (4 visible/NIR channels)
- 3.9 – 13.4 $\mu$ m (8 IR channels)

Resolution from 36 000 km altitude:

- 1 km for the high resolution visible channel
- 3 km for the infra-red and the 3 other visible channels

Focal plane is cooled to 85/95 k

One image every 15 minutes

245 000 images over 7 years nominal lifetime

Instrument mass: 260 kg

Dimensions:

- 2.43 m height
- 1 m diameter without Sun Shield

Power consumption: 150 W

Data rate: 3.26 Mbit/s

The Imaging Radiometer SEVIRI main features correspond to permanent imaging of the Earth using 12 spectral channels with a baseline repeat cycle of 15 minutes. The imaging spatial resolution is 3 km at sub-satellite point for standard channels and down to 1 km for the High Resolution Visible (HRV) channel.

The SEVIRI main unit is shown in Figure 1.

The 12 imaging channels are described as follows:

- Two visible channels VIS 0.6 and VIS 0.8 to provide cloud and land surface imagery during daytime. These wavelengths help in the discrimination of vegetated surfaces from clouds at different periods of the year and in the determination of the vegetation index and aerosol loads.
- The NIR1.6 channel is used to discriminate clouds from snow and water clouds from ice clouds. In combination with the 2 visible channels VIS0.6 and VIS0.8, it improves the observation of aerosol, soil moisture and vegetation index.

- The HRV Channel is implemented in support of the now-casting.
- IR6.2 and IR7.3 channels are used to determine the water vapour distribution in two distinct layers of the atmosphere. They are also used in combination with the long wave IR window channels for temperature determination of thin clouds (which can appear warmer than they are because of earth background) and wind determination in cloud free areas.
- The four channels IR3.8, IR8.7, IR10.8 and IR12.0 provide continuous cloud observation along with a temperature estimate of clouds, land and sea surfaces. IR3.8 is especially used at night to detect fog and very low clouds (it is less useful during daytime as the sun illumination is not negligible at this wavelength).
- Channels IR9.7 and IR13.4 are used to meet the Air Mass Analysis mission and improve the Basic Multi-Spectral Imaging, Cloud Motion Vectors and Surface Parameter Performances.
- Channel IR 9.7 belongs as well to the ozone absorption band and is used for the monitoring of the upper atmosphere, mainly tropopause features and stratospheric winds. It may also monitor the total ozone content.
- IR13.4 lies in the CO<sub>2</sub> absorption band and is intended to being used for cirrus discrimination, cloud top pressure evaluation, a cloud track and wind height assignment.

### **3. SEVIRI Operating Principle and Design Characteristics**

#### **3.1 The SEVIRI Operating Principle**

The following describes the instrument operating principle. The scan mirror is used to move the instrument Line Of Sight (LOS) along the South-North direction. The target radiance is collected by the telescope and focused onto the detectors. The Channel separation is performed at telescope focal plane level, by means of folding mirrors. A flip-flop type mechanism is periodically actuated to place the IR calibration reference source into the instrument field of view. The image data are directly transferred from the Main Detection Unit (MDU) to the onboard data handling subsystem. The Functional Control Unit (FCU) controls the SEVIRI functions and provides the TM/TC interfaces with the satellite.

The Earth imaging is obtained by a bi-dimensional Earth scan combining the satellite spin and the scan mirror rotation (Figure 2):

- The rapid scan (line scan) is performed from East to West thanks to the satellite rotation around the spin axis (spin rate at 100 rotations per minute). The spin axis is perpendicular to the orbital plane and is nominally oriented along the South-North direction.
- The slow scan is performed from South to North by means of a scan mechanism, which rotates the scan mirror in step rates of 125.8 micro radians. A scan total range of +/-5.5 degrees (corresponding to 1527 scan lines) is considered to cover the 22 degrees Earth imaging extended range in the South-North direction, respectively 1249 scan lines to cover the whole Earth in the baseline repeat cycle.

The full Earth disc image is obtained in about 12 minutes. The scan mirror is then driven back to its initial position and the flip-flop mechanism is activated to insert the on-board black body into the optical path for the instrument calibration. The black body is removed after about 2 seconds from the calibration position. The Earth observation is resumed leading to an overall repeat cycle of 15 minutes.

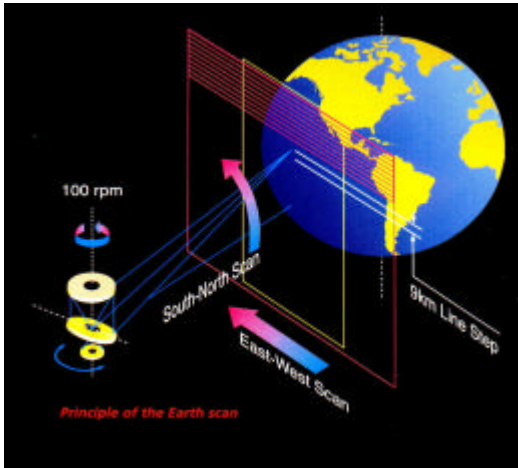

Figure 2: Earth Imaging Principle

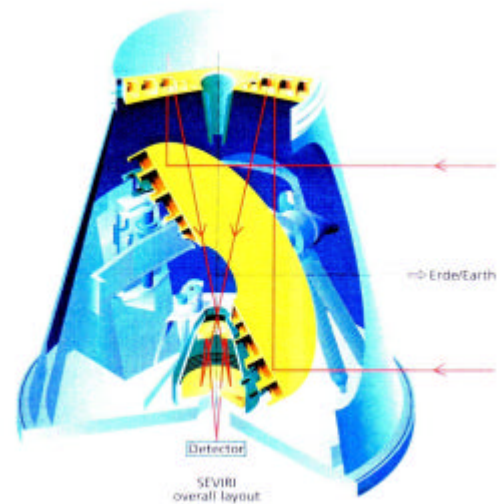

Figure 3: SEVIRI Mirror Concept

### 3.2 SEVIRI Design Characteristics

The SEVIRI instrument is composed of the Telescope and Scan Assembly (TSA), the Focal Plane and the Cooler Assembly (FPCA), the Electronic Unit Assembly (EUA) consisting of the Functional Control Unit (FCU) and the Detection Electronics (DE).

#### 3.2.1 The Telescope and Scan Assembly

The Telescope and Scan Assembly includes the telescope optics, the telescope structure and the mechanism assemblies. The basic optical layout of the telescope is based on a three-mirror concept as shown in Figure 3.

- M1: large Primary Mirror, concave a-spherical, with 510mm optical useful diameter,
- M2: Secondary Mirror, concave a-spherical, of 200 mm diameter,
- M3: Tertiary Mirror, convex a-spherical, of 60 mm diameter.

The required focal length (5367 mm) is obtained by successive magnification of the two mirrors M2 and M3. The total length of the telescope structure amounts to 1.3 m.

The Scan Mirror is located in front of the Primary Mirror, close to its focal plane, with a tilt of  $45^\circ$  relative to the optical path. The mirror has an elliptical shape (410 mm semi-major axis and 260 mm semi-minor axis) and an elliptical central hole, which allows the optical beam to pass through after its reflection towards the primary mirror M1.

All mirrors are light-weighted and manufactured from Zerodur.

The telescope structure relies on the use of a central stiff baseplate, which interfaces with the spacecraft via three isostatic mounts. The baseplate is manufactured from a 70mm Aluminum honeycomb sandwich, including CFRP face sheets of 4 mm thickness on each side. Each functional component is attached to the baseplate through a dedicated support structure.

The mechanical design of SEVIRI includes three mechanism assemblies: the Scan Mirror Assembly, the Calibration Unit and the Refocusing Mechanism. The Scan Assembly includes the Zerodur scan

mirror, a scan support structure mainly manufactured from CFRP, and the scan assembly mechanisms, which are mainly composed of:

- a linear spindle drive utilizing a stepper motor,
- a kinematic link system which transfers the longitudinal movements of the linear spindle drive into rotations at scan mirror level,
- a set of angular contact ball bearings (dry lubricated) allowing for small oscillatory rotations of the scan mirror,
- a set of springs attached to the mirror rotation axis to allow for spin load compensation in-orbit,
- and a dedicated Launch Locking Device (LLD) to clamp the scan mirror during launch.

The main purpose of the CALibration Unit (CALU) is to allow the calibration of the IR channels of the radiometer by inserting a Black Body Calibration Reference Source (CRS) into the optical beam at M1 focal point. The CALU represents a flip-flop type of mechanism based on a DC voice coil motor. To limit the shock loads when reaching the rest positions, dedicated shock absorbers are used.

The REfocusing Mechanism (REM) allows for in-orbit focus adjustments (in steps of 1.4 micrometer within the range of 2 mm) by moving the M2/M3 mirror assembly along the instrument South-North axis. The REM features a stepper motor, a transmission gearbox and a roller screw providing the translation. The mechanical linear guide is provided by the elastic deformation of a 6-blade arrangement.

### **3.2.2 The Focal Plane and Cooler Assembly**

The Focal Plane and Cooler Assembly (FPCA) is composed of the Passive Cooler Assembly (PCA), a two-stage passive cooling equipment, the Radiator Assembly (RA) and the Sunshield Assembly (SA), which provide the IR detectors with a cryogenic environment (basically 85K in summer period and 95K in winter period). A sunshield is used to avoid direct solar fluxes on the first and second stage radiator. Further, thanks to the design of the internal cone (elliptically shaped), the secondary flux on the second stage radiator is reduced. The PCA heat radiation towards the cold deep space is in the range of 10mW to 10W. One of the most critical subsystems of the RA is the Detection Cold Wiring (DCW), which provides the electrical connection between the detectors located at the Cold InfraRed Optical bench (CIRO) and the warm part of the instrument. The DCW needed to be optimized in order to comply with the electrical requirements whilst minimizing the thermal impact due to conductive losses (about 200K thermal gradient between cold part and warm part of the RA). Structurally, the CIRO is thermally de-coupled from the warm part by a set of low conductive suspensions (12 GFRP struts) and a dedicated GFRP cone. The PCA is equipped with heaters, in order to allow for periodic decontamination operations of the instrument (to remove frozen contaminants from the cold surfaces).

The architecture of the Radiator Assembly (RA) is presented in Figure 4.

The Focal Plane Optical Benches (FPOB) are designed to accommodate the 12 channels of SEVIRI. It consists of two main assemblies: the VNIR and HRV Optical bench (VHRO) for the 4 visible channels and the Warm/Cold IR Optical bench (WIRO/CIRO) for the 8 Infrared Channels. Figure 5 shows the CIRO layout including its optical components and wiring. The CIRO will be thermally regulated at 85 K and 95 K depending on the solstices and on the cooler capabilities during the MSG lifetime, whilst the VHRO is regulated at 20°C.

The FPOB support the detectors and perform the appropriate imaging after the in-field beam separation at the telescope focal plane level. Thus, most of the SEVIRI spectral, geometric and radiometric performances rely on the FPOB design and performances.

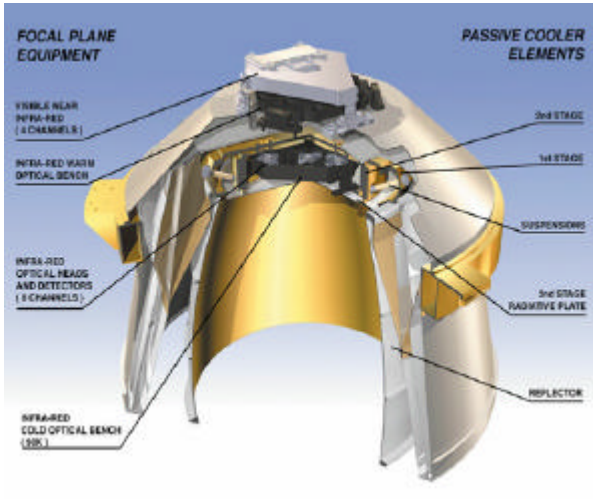

Figure 4: Radiator Assembly with Optical Benches

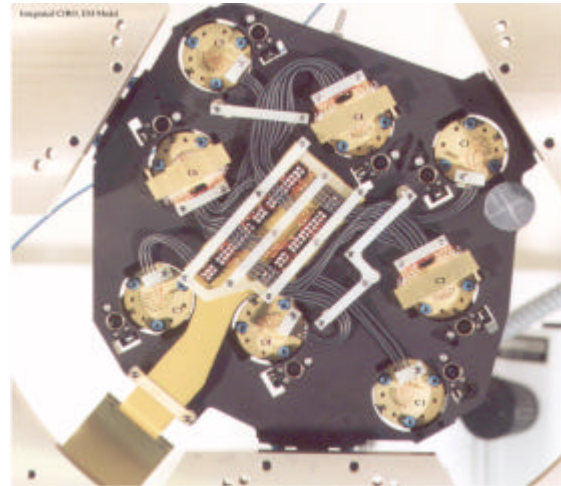

Figure 5: CIRO Equipped with Cold Channels and Wiring

### 3.2.3 The Electronic Unit Assembly

The Electronic Unit Assembly (EUA) controls SEVIRI and processes its data. It consists of 3 electronic boxes located on the satellite main platform. These are the FCU and the Detection Electronics (DE) consisting of the Main Detection Unit (MDU) and the Preamplifier Unit (PU).

The Functional Control Unit (FCU) is in charge of the SEVIRI command and control and it interfaces with the MSG spacecraft on-board data handling subsystem.

The FCU consists of three major sections. The core section including the functional mode and sequence management, the mechanism section (electronics driving the mechanisms), and the heater and telemetry section dedicated to thermal control management as well as TM conditioning and management.

The Detection Electronics (DE) consists furthermore of the detectors and the front end electronics called Cold Unit (CU) located near the IR optical bench and the Warm Unit (WU) near the visible optical bench.

The SEVIRI electrical architecture is shown in Figure 6.

The 12 SEVIRI Channels consist of 8 InfraRed (IR) detector packages (3 detectors each), and 1 High Resolution in the Visible (HRV) channel (9 detectors), 2 Visible and 1 Near IR (3 detectors each). The IR detectors are all made of Mercury Cadmium Telluride, the visible detectors are in Silicon and the NIR are made of Indium Gallium Arsenide. The detectors are shaped and sized to satisfy both, the radiometric and imaging performances of the SEVIRI Instrument.

The Pre-amplifier Unit (PU) first amplifies the signal acquired by each detector of the 42 chains. The PU uses a generic design with a modular approach common to all PhotoVoltaic (PV) and PhotoConductive (PC) amplifiers. This subsystem consists of three assemblies:

- The Cold Unit (CU) containing the front-end parts of the IRPV chains. This trans-impedance amplifier, common to all PV chains, is implemented for impedance matching and for low noise amplification.
- The Warm Unit (WU) is devoted to the front-end parts of HRV/VNIR preamplifiers.
- The PU main box contains the remaining electronics dedicated to shape the analog signal to the specified values and it includes TM/TC interfaces.

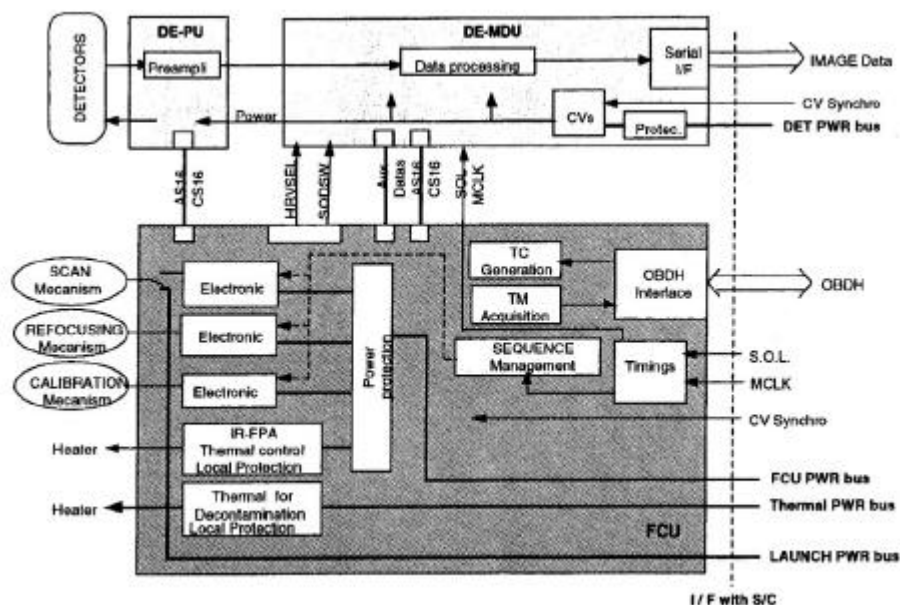

Figure 6: Electrical Architecture

The MDU contains the signal processing electronics including signal conditioning, anti-aliasing filtering, sampling and conversion of the analog signals into the digital signals. The sampling delays are adjustable via telecommand. This applies to all the 42 chains of SEVIRI. The actual quantisation is made inside the MDU by a 12 bits ADC, for an effective 10 bit resolution at the electronics output, after digital dynamic offset and fine gain corrections. Auxiliary data coming from the telemetry, which are needed for radiometry and image processing, are added to the detection data for image processing on-ground.

A star sensing function is implemented in the MDU. It is activated whenever the star sensing windows are telecommanded. No processing at SEVIRI level (filtering and dynamic offset correction) is applied to the star sensing function. This raw data is sent to the S/C in the way as any other auxiliary data.

#### 4. SEVIRI Performance Verification

The on-ground calibration of the imaging radiometer is performed by using dedicated Optical Ground Segment Equipment (OGSE). However, the limitation of the OGSE made the calibration a very difficult task. This calibration is used for the on-ground gain determination process as described in Ref. 2.

##### 4.1 SEVIRI PFM On-Ground Characterisation: Test Results

This chapter will discuss the test results obtained from the various characterisations at ambient and in the thermal vacuum environments. It includes the radiometric and imaging performances, carried out at SEVIRI level. This paper was written when only the engineering model satellite characterisation data were available. However, it can be stated that the performances show no significant differences between the results obtained at SEVIRI level and those obtained at MSG level. The detailed description of the radiometric and imaging performance processing can be found in Ref. 2. This paper will only present the test results obtained at SEVIRI PFM level.

### 4.1.1 Radiometric Performance Characterisations

The SEVIRI instrument radiometric performance characterizations focus onto the determination of parameters such as Radiance Response (RR) and its associated non-linearities, the validation of the on-board calibration process and the measurements of radiometric noise and drift. The SEVIRI radiometric performances are verified with constant and uniform targets as specified at system level. The image data mean value (corresponding to one line) consists of samples coded over 10 bits, ranging from 0 to 1023. This ends up to 5751 samples for each HRV chain and 3834 samples for each of the other detection chains. A set of data is defined as the concatenation of the data lines corresponding to several consecutive Earth Acquisition Windows and corresponding to the same configuration (i.e. same illumination level and same detection chain parameter settings).

Channel ( $\mu\text{m}$ )	HRV	0.6	0.8	1.6	3.9	6.2	7.3	8.7	9.7	10.8	12.0	13.4
Noise	0.52	0.39	0.36	0.08	0.24	0.40	0.48	0.15	0.24	0.13	0.21	0.29
Spec.	1.07	0.53	0.49	0.25	0.35	0.75	0.75	0.28	1.50	0.25	0.37	1.80

**Table 1:** PFM Noise budgets as measured at the beginning of life. For end of life, about 30% to 50% margin is available, depending on channels. The noise performances displayed are expressed as NE $\Delta$ T (in Kelvin) for IR channels and as NE $\Delta$ R (in  $\text{W}/\text{m}^2.\text{sr}.\mu\text{m}$ ) for Visible and NIR channels.

For all the radiometric test results (spectral response, radiance response and noise), negligible differences are found between operational temperatures of the IR focal plane at 85K and 95 K.

### 4.1.2 Imaging Performance Characterisations

In this paragraph, one has to distinguish between 2 types of tests even though the two of them are linked:

- the geometric imaging performed mostly at ambient environment for the determination of the stability of the line of sight of SEVIRI before and after environmental tests such as thermal vacuum and vibrations ;
- the Spatial Frequency Response (SFR), the sampling distance and the co-registration that are considered as opto-electronic imaging tests are performed in thermal vacuum.

The Central Line Of Sight (CLOS) instability due to thermo-elastic distortions of the radiometer is the most important contributor to the instrument geometric imaging errors. The CLOS stability is measured in vacuum at two extreme temperatures of the telescope thermal cases during the SEVIRI thermal vacuum test. The results of this measurement were used for the SEVIRI geometric performance verification whilst validating the thermo-elastic model.

From the KEF in both E/W and S/N directions (performed in thermal vacuum), the position of the detectors used for the CLOS definition in the OGSE image frame have been computed, giving the corresponding detector pointing directions in the OGSE frame for both thermal cases. The evolution of the radiometer reference cube orientation to the OGSE cube when compared for both thermal cases, gives the SEVIRI global rotation with respect to the OGSE frame. By subtracting the SEVIRI global rotation to the CLOS pointing variation, it is possible to deduct the pointing variation in the radiometer frame. Using the above-described methods, the stability of SEVIRI is demonstrated as far as the line of sight and its overall geometric parameters are concerned.

The SFR determination objectives are two-fold:

- to provide on-ground characterisation allowing to determine the SEVIRI Radiometer/Imager Modulation Transfer Function (MTF) ;
- to provide on-ground measurements for the verification and characterisation of the SEVIRI co-registration error (including its internal IFOV sampling accuracy, namely pixel positions).

All the MTF (amplitude of the SFR) measurements (KEF and dynamic MTF) are within their specifications with enough margins to allow absorbing measurement errors and focus evolution during in-orbit lifetime. The most sensitive channel is HRV. However, with a defocus of up to 2.8 mm, the HRV channel still meets the specification. All the measured MTF's are very close to the predicted values. This allows determining a very good correlation between the mathematical model and the measurements. It is in addition demonstrated that the MTF is very stable with respect to the simulated thermal environment and this during the whole test duration. In the following graphs (Fig. 7 and Fig.8), one can see the results of the MTF characterisations. Thus, the stability of SEVIRI is demonstrated for all the specified environments. The determination of the best focus between the different phases of the test was also performed thanks to the refocusing mechanism in the SEVIRI design. After that, it is demonstrated through the various test phases that the focus of the MSG imaging radiometer is stable for all channels, in all the specified environmental conditions.

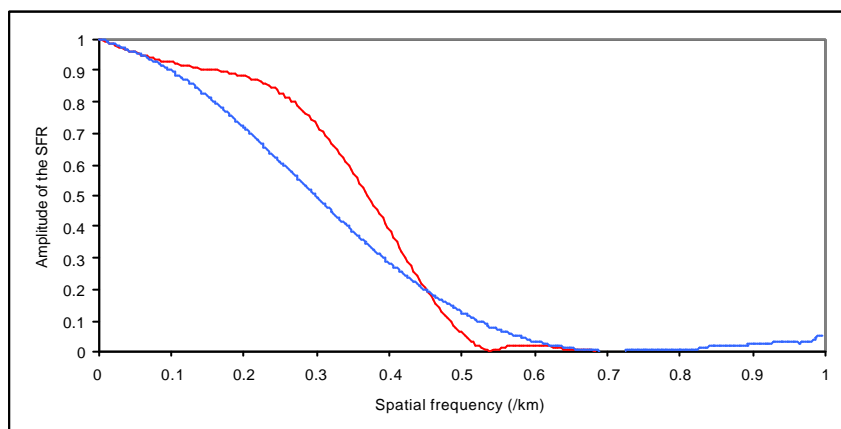

Fig. 7: MTF measurement results for HRV (Red is East/West and Blue is South/North)

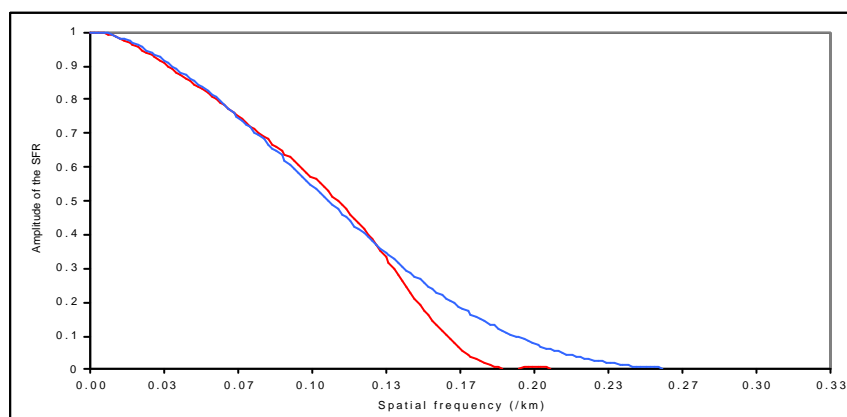

Fig. 8: MTF measurement results for IR3.9 channel (Red is East/West and Blue is South/North).

## 5. Conclusion

This paper described the SEVIRI design and the environmental tests approach applied to assess the SEVIRI performances at PFM Instrument and the EM satellite level. The tests performed have demonstrated that the instrument meets the performances in all specified environments. In radiometry, including noise, long term drift and spectral responses, all the specifications are met for the beginning of life. When margins and sensitivity analyses are applied both experimentally and by computation, it shows that the end of life performances will be also met. The on-board calibration process has been validated which is one of the main parameters for securing the absolute radiometry. The imaging requirements (MTF, S/N and E/W sampling distances, co-registration, etc.) are met as well with margins large enough to meet the end of life performances. In addition, the instrument focus and its pointing stability are within the specifications with large margins. The test results of the SEVIRI Proto-Flight Model indicated the qualification for flight of the developed Imaging Radiometer with respect to the requirements. The satellite flight model (MSG-1) at present has been submitted to electrical and thermal vacuum test. Optical test will be performed by the end of June 2000.

## Acknowledgements

The author would like to thank the entire MSG/SEVIRI team from ESA, Alcatel Space Industries and Matra Marconi Space for their support and contribution to the analyses and testing. Special thanks to all the system engineers who contributed to the development of the Imaging Radiometer SEVIRI.

## References

1. D. M. A. Aminou, B. Jacquet and F. Pasternak  
'Characteristics of the Meteosat Second Generation Radiometer/Imager :SEVIRI' Proceedings of SPIE, Europto series, Vol. 3221 pages 19-31.
2. D. M. A. Aminou, A. Ottenbacher, B. Jacquet and A. Kassighian  
'Meteosat Second Generation : On-ground Calibration, Characterisation and Sensitivity Analysis of the SEVIRI Imaging Radiometer'. Proceedings of SPIE « Earth Observing Systems IV », Vol. 3750, page 419-430.
3. ESA, MSG Web Site : <http://www.esa.int/msg/>